

Direct Drive Remote Air-Cooled Fluid Coolers

33 Models



Model AFV with Vertical Air Discharge
Also available in AFH Models with Horizontal Discharge

“The Heat Transfer Experts”

TABLE OF CONTENTS

	FIGURES	TABLES	PAGE
Features and Options			3
Nomenclature			3
Specifications			
Physical Specifications		Table 1	4
Electrical Specifications		Table 2	5
Dimensions, Models 62 thru 384	Fig 1		6
Dimensions, Models 119 thru 636	Fig 2		7
Dimensions, Models 714 thru 1271	Fig 3		8
Dimensions, Models 1425 thru 1625	Fig 4		9
50 Hz Operation		Table 3	10
Fan Speed/Sound Level		Table 4	10
Selection Procedure			
Glossary of Terms			11
Selection Example			12
Notes			13
Suggested Connection Sizes based on GPM		Table 5	13
Optional Fan Control			13
Fluid Heat Factors	Fig 5		14
Capacity Correction Factors	Fig 6		14
Fluid Pressure Drop	Fig 7		15
Pressure Drop Correction Factors	Fig 8		16
Altitude Correction Factor	Fig 9		16
(1) Fan Fluid Coolers	Fig 10		17
(2) Fan Fluid Coolers	Fig 11		18
(3) Fan Fluid Coolers	Fig 12		19
(4) Fan Fluid Coolers	Fig 13		20
(5) & (6) Fan Fluid Coolers	Fig 14		21
(8) Fan Fluid Coolers	Fig 15		22
(10) Fan Fluid Coolers	Fig 16		23

STANDARD FEATURES:

Colmac AFV/AFH model air-cooled fluid coolers are designed to provide cooling of Water, Ethylene Glycol/Water and Propylene Glycol/Water mixtures in a variety of closed-loop applications. Closed-loop cooling eliminates the cost of fluid treatment usually associated with the use of cooling towers.

- Wide range of models and capacities - 33 models.
- Corrosion resistant construction - Mill galvanized housing, powder coated steel fan guards, aluminum fan blades on 3/4 Hp models, galvanized steel fan blades on 1 & 2 Hp models. Low speed, fully guarded fans for quiet operation.
- Built-in lifting eyes, and easy-to-install legs, make rigging and installation fast.
- Low noise, 850 RPM fans, on 1 & 2 Hp models.
- Compartmented fans to prevent short circuiting of air during fan cycling.
- Units designed for efficient fan cycle control.
- Versatile cabinet design for vertical or horizontal airflow.
- Coil is made of 1/2" dia seamless copper tubes, and high efficiency aluminum plate fins, with self-spacing collars.
- Exclusive Colmac "Full Floating Core" coil support system eliminates tubesheet leaks by shifting support of the coil core from tubes to fins. Special "Wear Guards" allow expansion and contraction of fins and tubes without chafing or wearing of tubes, or fins.
- Heavy duty rigid foot-mounted direct drive fan motors with moisture protected rainshields (slingers) are internally protected single or three phase on models 62 thru 384 (3/4 Hp), internally protected three phase only on models 119 thru 1271 (1 Hp), and three phase externally protected only on models 1425 thru 1625 (2 Hp). Motors are rated for 150°F maximum air temperature over the motor.
- Weatherproof electrical enclosure features single point field wiring, and is easily accessible for fast installation.

OPTIONS:

- Copper fins, or Polycoat Fins for corrosion resistance.
- Stainless or galvanized steel fan blades or cast aluminum.
- Stainless steel housing.
- Factory mounted and wired fused disconnect.
- Factory wired fan cycle/fan speed control.
- Customer specified control systems.
- Baked phenolic coating available
- UL 508 listed electrical panels
- CSA listing available

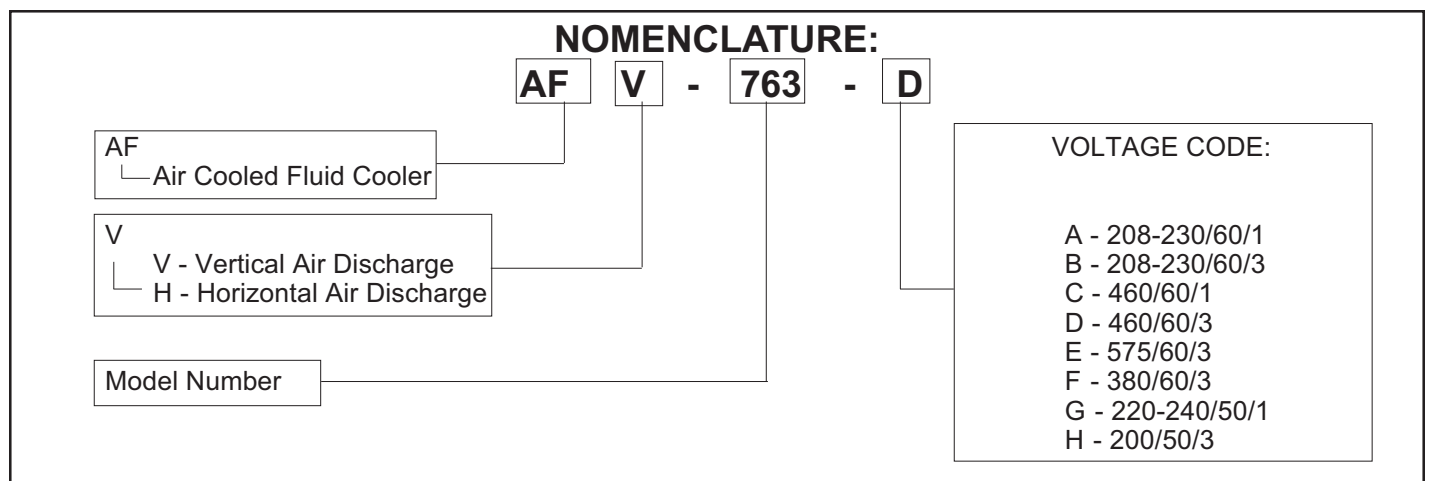

TABLE 1
AFV/AFH PHYSICAL SPECIFICATIONS

Model	Fan Dia. in.	No. Fans	CFM	Coil Face	Rows Deep	Fins/ Inch	Internal Vol. Cu/Ft.	Wt. (lbs.) of 40% Glycol Mixture @ 135°F		Dry Wt. lbs.
								Ethel.	Propyl.	
62	24	1	6310	35 x 48	2	14	0.324	21.0	20.5	330
84	24	1	6039	35 x 48	3	14	0.487	31.5	30.8	357
96	24	1	5734	35 x 48	4	14	0.649	42.0	41.1	383
167	24	2	12078	35 x 96	3	14	0.936	60.6	59.3	589
192	24	2	11468	35 x 96	4	14	1.25	80.9	79.1	643
251	24	3	18117	35 x 144	3	14	1.39	90.0	88.0	863
288	24	3	17202	35 x 144	4	14	1.85	119.8	117.1	944
307	24	4	24800	35 x 192	3	11	1.84	119.1	116.5	1056
335	24	4	24156	35 x 192	3	14	1.84	119.1	116.5	1096
384	24	4	22936	35 x 192	4	14	2.45	158.6	155.1	1203
119	30	1	8620	45 x 54	3	14	0.698	45.2	44.2	513
127	30	1	8090	45 x 54	4	14	0.931	60.3	58.9	552
223	30	2	18060	45 x 108	3	11	1.35	87.4	85.5	815
238	30	2	17240	45 x 108	3	14	1.35	87.4	85.5	843
254	30	2	16180	45 x 108	4	14	1.80	116.5	114.0	921
357	30	3	25860	45 x 162	3	14	2.00	129.5	126.6	1242
381	30	3	24270	45 x 162	4	14	2.66	172.2	168.4	1358
446	30	4	36120	45 x 216	3	11	2.65	171.5	167.8	1516
476	30	4	34480	45 x 216	3	14	2.65	171.5	167.8	1572
509	30	4	32360	45 x 216	4	14	3.53	228.5	223.5	1728
595	30	5	43100	45 x 270	3	14	3.30	213.6	208.9	1971
636	30	5	40450	45 x 270	4	14	4.40	284.8	278.6	2165
714	30	6	51720	90 x 162	3	14	4.00	258.9	253.2	2374
763	30	6	48540	90 x 162	4	14	5.32	344.4	336.8	2607
893	30	8	72240	90 x 216	3	11	5.30	343.1	335.5	2927
952	30	8	68960	90 x 216	3	14	5.30	343.1	335.5	3040
1017	30	8	64720	90 x 216	4	14	7.06	457.0	447.0	3351
1116	30	10	90300	90 x 270	3	11	6.60	427.2	417.8	3661
1190	30	10	86200	90 x 270	3	14	6.60	427.2	417.8	3803
1271	30	10	80900	90 x 270	4	14	8.80	569.6	557.1	4191
1425	36	10	111900	90 x 270	3	14	6.60	427.2	417.8	4368
1502	36	10	101600	90 x 270	4	14	8.80	569.6	557.1	4756
1625	36	10	88000	90 x 270	6	14	13.20	854.4	835.7	5532

Notes:

1. Weight of Liquid is calculated as follows:
Wt. Liquid (lbs) = Internal Vol. (cu. ft.) x Liquid Density(lbs/cu ft)
2. Operating Weight = Dry Weight + Weight Liquid
3. Units having finned length up to 216" use 1/2 x 0.016 copper tubes.
Units having finned length of 270" use 1/2 x 0.025 copper tubes.

TABLE 2
AFV/AFH ELECTRICAL SPECIFICATIONS

Model	Fan dia,in.	No. Fan	Fan Hp	Total FLA/60 Hz Supply				Total FLA/50 Hz Supply	
				208-230/1	208-230/3	460/1	460/3	Note 3 200/3	400/3
62	24	1	3/4	3.9	3.40	1.9	1.55	4.2	2.1
84	24	1	3/4	3.9	3.40	1.9	1.55	4.2	2.1
96	24	1	3/4	3.9	3.40	1.9	1.55	4.2	2.1
167	24	2	3/4	7.8	6.80	3.8	3.10	8.4	4.2
192	24	2	3/4	7.8	6.80	3.8	3.10	8.4	4.2
251	24	3	3/4	11.7	10.20	5.7	4.65	12.6	6.3
288	24	3	3/4	11.7	10.20	5.7	4.65	12.6	6.3
307	24	4	3/4	15.6	13.60	7.6	6.20	16.8	8.4
335	24	4	3/4	15.6	13.60	7.6	6.20	16.8	8.4
384	24	4	3/4	15.6	13.60	7.6	6.20	16.8	8.4
119	30	1	1	note 1	5.6	note 1	2.8	4.2	2.1
127	30	1	1	"	5.6	"	2.8	4.2	2.1
223	30	2	1	"	11.2	"	5.6	8.4	4.2
238	30	2	1	"	11.2	"	5.6	8.4	4.2
254	30	2	1	"	11.2	"	5.6	8.4	4.2
357	30	3	1	"	16.8	"	8.4	12.6	6.3
381	30	3	1	"	16.8	"	8.4	12.6	6.3
446	30	4	1	"	22.4	"	11.2	16.8	8.4
476	30	4	1	"	22.4	"	11.2	16.8	8.4
509	30	4	1	"	22.4	"	11.2	16.8	8.4
595	30	5	1	"	28.0	"	14.0	21.0	10.5
636	30	5	1	"	28.0	"	14.0	21.0	10.5
714	30	6	1	note 1	33.6	note 1	16.8	25.2	12.6
763	30	6	1	"	33.6	"	16.8	25.2	12.6
893	30	8	1	"	44.8	"	22.4	33.6	16.8
952	30	8	1	"	44.8	"	22.4	33.6	16.8
1017	30	8	1	"	44.8	"	22.4	33.6	16.8
1116	30	10	1	"	56.0	"	28.0	42.0	21.0
1190	30	10	1	"	56.0	"	28.0	42.0	21.0
1271	30	10	1	"	56.0	"	28.0	42.0	21.0
1425	36	10	2	note 1	86.0	note 1	43.0	93.7	46.9
1502	36	10	2	"	86.0	"	43.0	93.7	46.9
1625	36	10	2	"	86.0	"	43.0	93.7	46.9

Notes:

1. These units not available for single phase supply.
2. Models 62 through 384 (24" Fans)
Standard motors are 3/4 HP, 1140 RPM ODP, 60 Hz with internal thermal overload protection.

Models 119 through 1271 (30" Fans)
Standard motors are 1 HP, 850 RPM ODP, 60 Hz with internal thermal overload protection.

Models 1425 through 1625 (36" Fans)
Standard motors are 2 HP, 850 RPM TEFC, 60 Hz without internal thermal overload protection.
3. For 50 Hz operation:
(see Page 10)
1 HP motors are used in lieu of 3/4 HP.
1-1/2 HP motors are used in lieu of 1 HP.
2 HP motors are 950 RPM, 2 HP.

FIGURE 1
PHYSICAL DIMENSIONS, Models 62 thru 384
(24" dia fans)

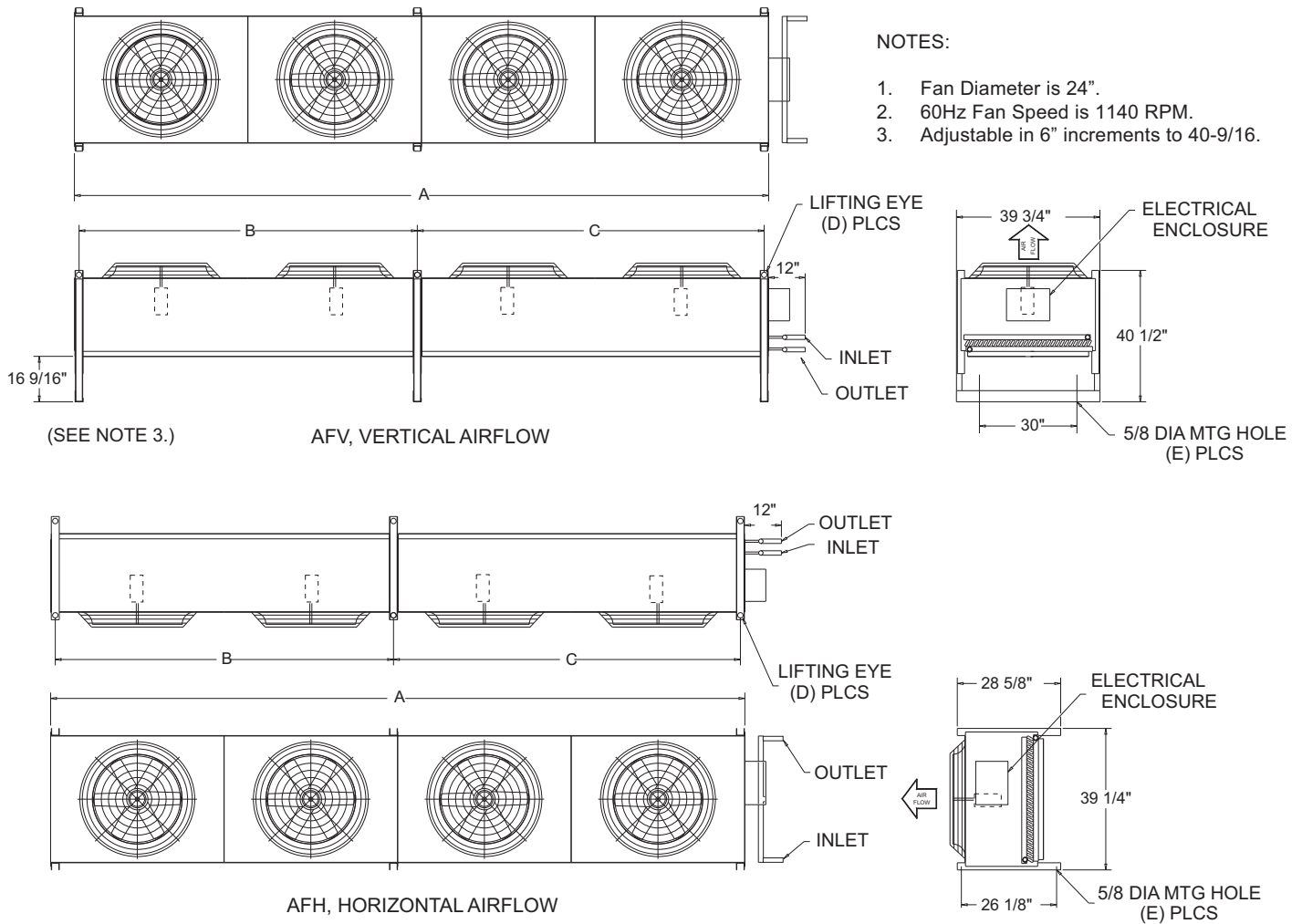

DIMENSIONS

MODEL	NO. FANS	A	B	C	D	E	MAX. INLET/OUTLET CONN. SIZE, MPT
62	1	48	46	-	4	4	3
84	1	48	46	-	4	4	3
96	1	48	46	-	4	4	3
167	2	96	94	-	4	4	3
192	2	96	94	-	4	4	4
251	3	144	94	48	6	6	4
288	3	144	94	48	6	6	4
307	4	192	94	96	6	6	4
335	4	192	94	96	6	6	4
384	4	192	94	96	6	6	4

FIGURE 2
PHYSICAL DIMENSIONS, Models 119 thru 636
(30" dia fans)

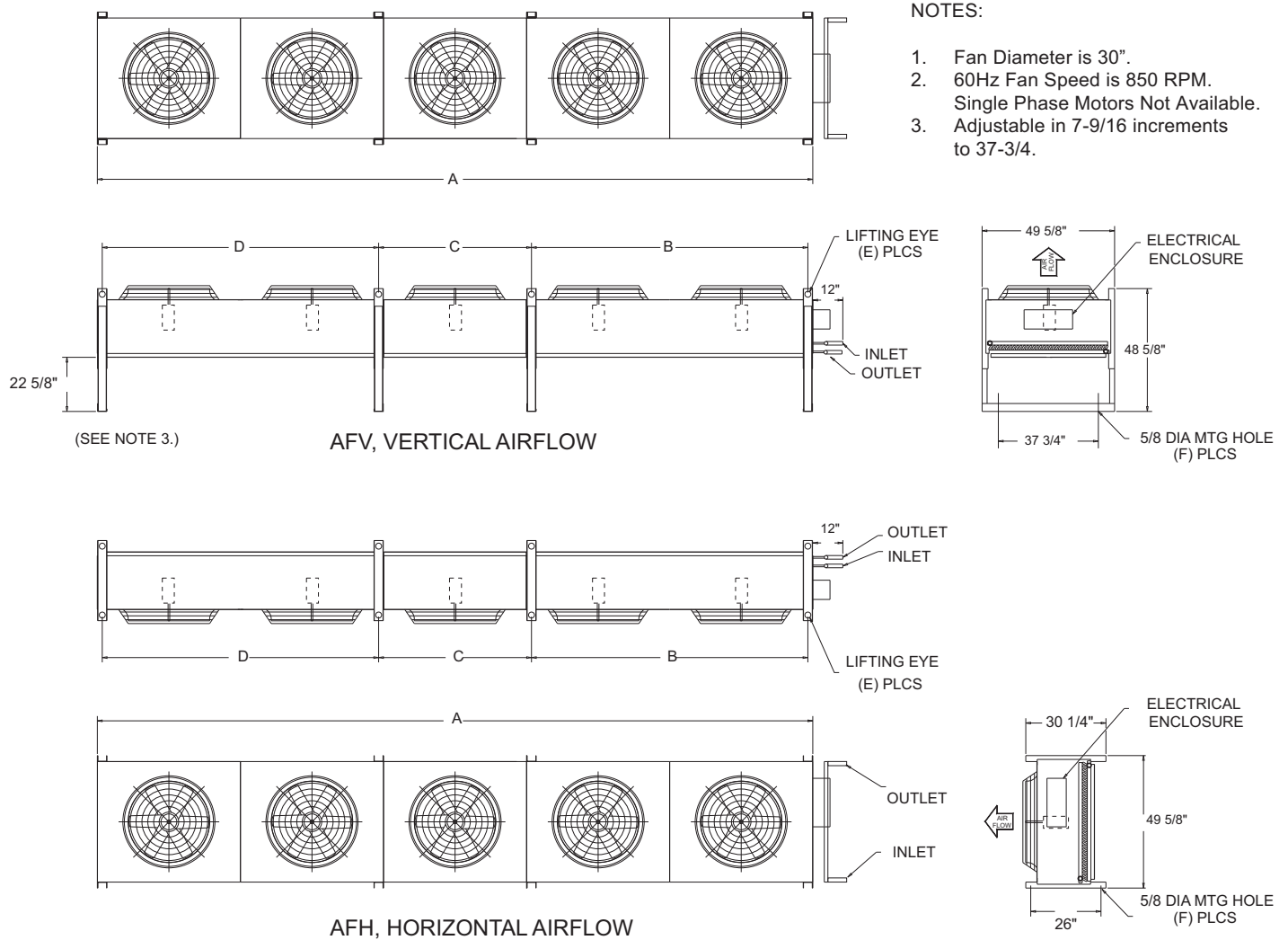

DIMENSIONS

MODEL	NO. FANS	A	B	C	D	E	F	MAX. INLET/OUTLET CONN. SIZE, MPT
119	1	54	50 1/2	-	-	4	4	4
127	1	54	50 1/2	-	-	4	4	4
223	2	108	104 1/2	-	-	4	4	4
238	2	108	104 1/2	-	-	4	4	4
254	2	108	104 1/2	-	-	4	4	4
357	3	162	104 1/2	-	54	6	6	4
381	3	162	104 1/2	-	54	6	6	4
446	4	216	104 1/2	-	108	6	6	4
476	4	216	104 1/2	-	108	6	6	4
509	4	216	104 1/2	-	108	6	6	4
595	5	270	104 1/2	57 1/2	104 1/2	8	8	4
636	5	270	104 1/2	57 1/2	104 1/2	8	8	4

FIGURE 3
PHYSICAL DIMENSIONS, Models 714 thru 1271
(30" dia fans)

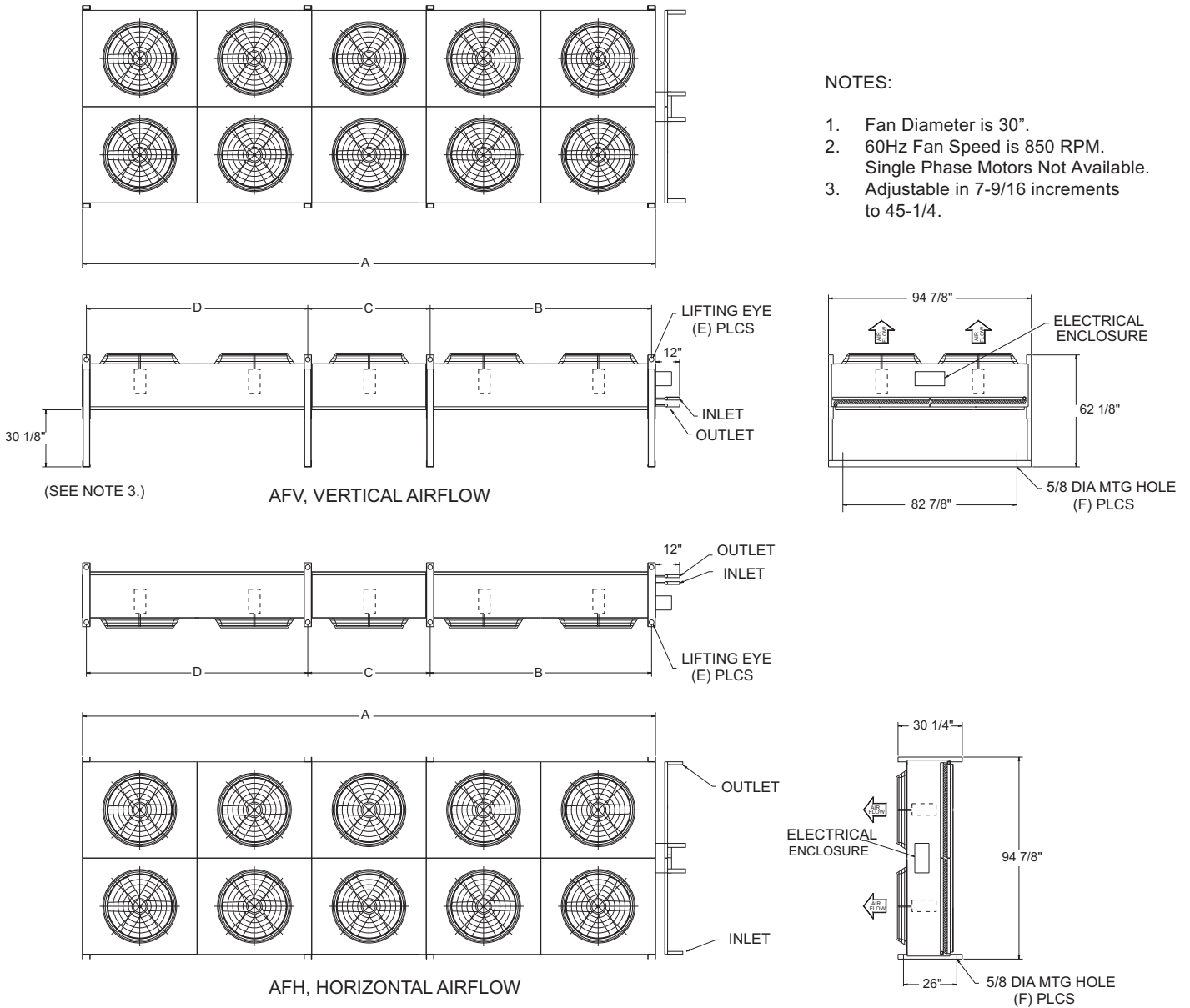

DIMENSIONS

MODEL	NO. FANS	A	B	C	D	E	F	MAX. INLET/OUTLET CONN. SIZES, MPT
714	6	162	104 1/2	-	54	6	6	5
763	6	162	104 1/2	-	54	6	6	6
893	8	216	104 1/2	-	108	6	6	5
952	8	216	104 1/2	-	108	6	6	5
1017	8	216	104 1/2	-	108	6	6	6
1116	10	270	104 1/2	57 1/2	104 1/2	8	8	5
1190	10	270	104 1/2	57 1/2	104 1/2	8	8	5
1271	10	270	104 1/2	57 1/2	104 1/2	8	8	6

FIGURE 4
PHYSICAL DIMENSIONS, Models 1425 thru 1625
(36" dia fans)

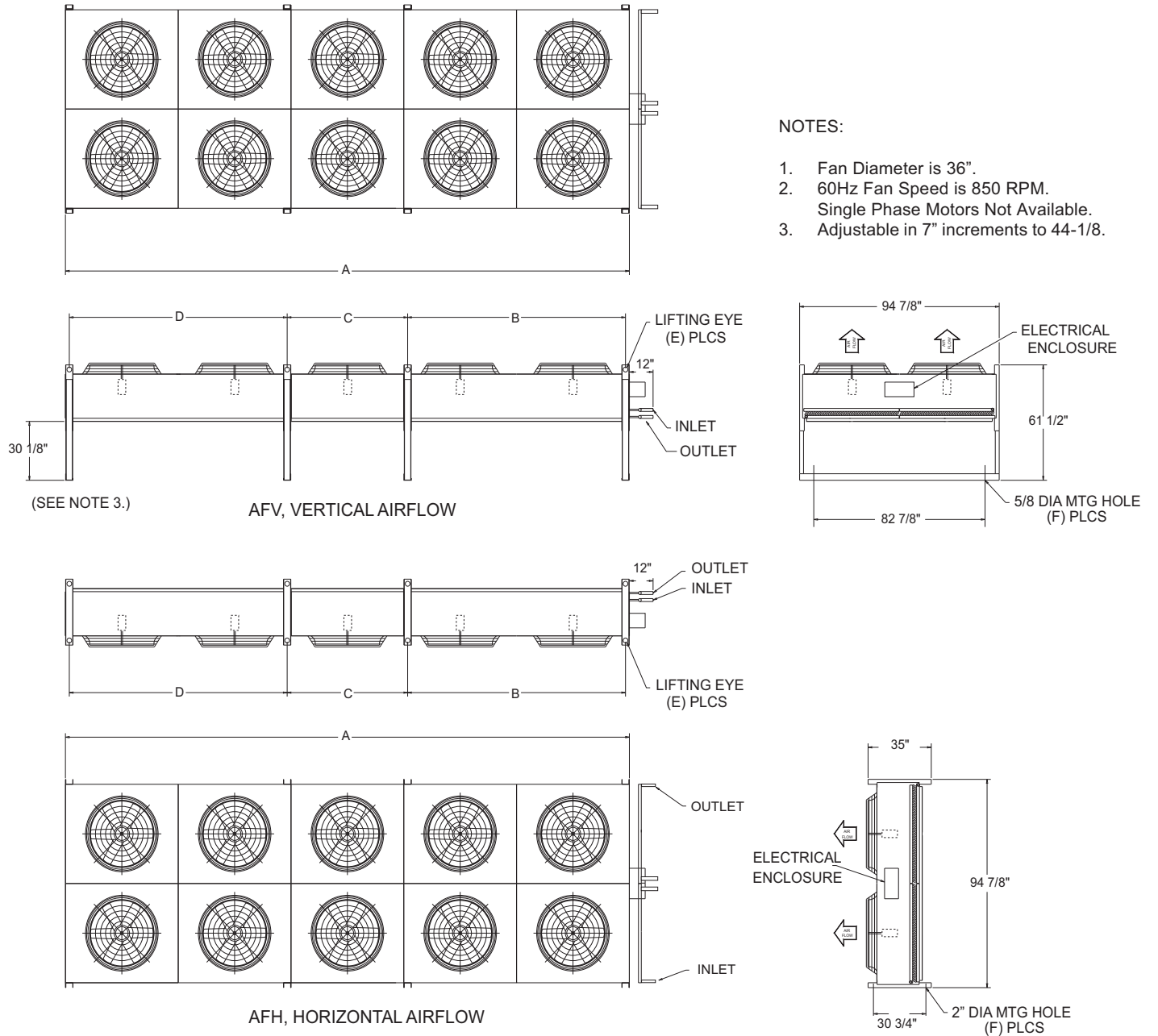

DIMENSIONS

MODEL	NO. FANS	A	B	C	D	E	F	MAX. INLET/OUTLET CONN. SIZES, MPT
1425	10	270	104 1/4	57 3/4	104 1/4	8	8	5
1502	10	270	104 1/4	57 3/4	104 1/4	8	8	6
1625	10	270	104 1/4	57 3/4	104 1/4	8	8	6

OPERATION WITH 50 Hz POWER

COLMAC AFV and AFH fluid coolers are designed to operate with either 60 Hz, or 50 Hz supply power. Cooling capacity for 50 Hz operation will be the same as capacity for 60 Hz operation, since COLMAC uses fan blades matched to the 50 Hz rotational speed of 950 RPM.

Motor horsepower on most models will be different, however. The 60 Hz, 3/4 HP motors will be replaced with 1.0 HP motors, and 60 Hz, 1.0 HP motors will be replaced with 1.5 HP motors for 50 Hz operation.

50 Hz FAN SPEED/SOUND LEVEL:

Operation of fluid coolers at 50 Hz will change the rotational speed of the fans. All fans will turn at 950 RPM. The 24 in. dia. fans will turn slower than those used for 60 Hz operation, and will run quieter. The 30 and 36 in. dia. fans will turn faster than those used for 60 Hz operation and will be somewhat louder. Fan and tip speeds, and sound levels for 60 Hz and 50 Hz are shown in tables 3 and 4.

**TABLE 3
FAN SPEEDS**

Models	Fan Dia	60 Hz		50 Hz	
		Fan RPM	Tip Spd FPM	Fan RPM	Tip Spd FPM
62 thru 384	24"	1140	7163	950	5969
119 thru 1271	30"	850	6676	950	7464
1425 thru 1625	36"	850	8011	950	8958

**TABLE 4
AFV/AFH SOUND LEVELS (Approx.)***

No. Fans	60 Hz Operation				50 Hz Operation			
	dBA @ Distance from Unit, Ft				dBA @ Distance from Unit, Ft			
	5'	25'	50'	100'	5'	25'	50'	100'
24 dia								
1	70	56	50	44	66	52	46	40
2	73	59	53	47	69	55	49	43
3	75	61	55	49	71	57	51	45
4	76	62	56	50	72	58	52	46
30 dia								
1	69	55	49	43	71	57	51	45
2	72	58	52	46	74	60	54	48
3	74	60	54	48	76	62	56	50
4	75	61	55	49	77	63	57	51
5	76	62	56	50	78	64	58	52
6	77	63	57	51	79	65	59	53
8	78	64	58	52	80	66	60	54
10	79	65	59	53	81	67	61	55
36 dia								
10	85	71	65	59	87	73	67	61

*Based on free field sound data, with no background noise.

SELECTION PROCEDURE:

The selection of a COLMAC AFV/AFH fluid cooler is mostly graphical and is easy to make.

Glossary of Terms

ACF	=	Altitude Correction Factor (Fig. 9)
CCF	=	Capacity Corr. Factor, Fluid Mixture (Fig. 6)
EAT	=	Entering Air Temp.
EFT	=	Entering Fluid Temp.
FF	=	Flow factor (Figs. 10 thru 16)
FHF	=	Fluid Heat Factor (Fig. 5)
GPM	=	Gallons per Minute
LAT	=	Leaving Air Temp.
LFT	=	Leaving Fluid Temp.
LF	=	Length factor (Figs. 10 thru 16)
MBH	=	BTUH x 1000
ΔP_{fluid}	=	Fluid Pressure Drop, psi (Fig. 7)
PDF	=	Pressure Drop Factor (Fig. 8)

Step 1. Calculate Avg Fluid Temp., AFT.

$$AFT = (EFT + LFT) / 2$$

Step 2. Calculate Fluid ΔT .

$$\Delta T = EFT - LFT$$

Step 3. Calculate temperature difference, TD

$$TD = EFT - EAT$$

Step 4. Find Fluid Heat Factor, FHF, (Fig. 5).

Step 5. Calculate MBH required per degree of temperature difference.

$$MBH / TD = (GPM \times \Delta T \times FHF) / TD$$

Step 6. Correct MBH / TD with CCF (Fig. 6) and ACF (Fig. 9).

$$MBH / TD = (MBH / TD) \times CCF \times ACF$$

Step 7. Choose Model, using GPM and MBH / TD in Figs. 10 thru 16.

** (Use Models whose performance curves fall on, or above MBH / TD)

Step 8. Find Fluid Pressure Drop:

- Using GPM, find FF and LF from Figure used in step 7.
- Using FF and LF, go to Fig. 7, to find ΔP_{fluid} .

Step 9. Correct Fluid Pressure Drop with PDF (Fig. 8).

$$\Delta P_{fluid} = \Delta P_{fluid} \times PDF$$

Step 10. (Optional) Unit capacity can be approximated by the following method:

$$MBH \text{ actual} = \frac{MBH/TD \text{ (Curve value)}}{CCF \times ACF} \times TD$$

EXAMPLE

1. $AFT = (125 + 115.5) / 2$
 $AFT = 120.3^{\circ}F$

2. $\Delta T = 125 - 115.5$
 $\Delta T = 9.5^{\circ}F$

3. $TD = 125 - 95$
 $TD = 30^{\circ}F$

4. From Fig. 5, we see that $FHF = 0.466$

5. Calculate $MBH / TD = (GPM \times \Delta T \times FHF) / TD$
 $MBH/TD = (80 \times 9.5 \times 0.466) / 30$
 $MBH/TD = 11.8$

6. Correcting capacity for 30% Eth. Gly. and 2,000 ft alt. using CCF (Fig. 6) and ACF (Fig. 9):
 $CCF = 1.002$ and $ACF = 1.04$

$MBH/TD = 11.8 \times 1.002 \times 1.04$
 $MBH/TD = 12.3$

7. Looking at Fig. 11, using 80 GPM and 12.3 MBH/TD:

a. Choose AFV-254 At 80 GPM, it's performance is 12.9 MBH/TD, which is greater than 12.3

b. Using diagrams in Fig. 11 for Flow Factor (above) and Length Factor, (side):
 for AFV-254 (Fig. 11): $FF = 3.33$
 $LF = 648$

8. Looking at Fig. 7, using 80 GPM, $FF = 3.33$ and $LF = 648$

$\Delta P_{fluid} = 7.5$

9. Correct for ΔP_{fluid} for 30% Eth. Gly mixture at $120^{\circ}f$ using Fig. 8: $PDF = 1.175$

$\Delta P_{fluid} = \Delta P_{fluid} \times PDF$
 $\Delta P_{fluid} = 1.175 \times 7.5$

$\Delta P_{fluid} = 8.8 \text{ psi}$

10. Actual Unit Capacity at 80 GPM, $120^{\circ}F$ AFT, $30^{\circ}TD$, and 30% Ethylene glycol, is approximately:

$$MBH \text{ actual} = \frac{MBH / TD}{CCF \times ACF} \times TD = \frac{12.9 \text{ MBH}/TD}{1.002 \times 1.04} \times 30$$

$MBH \text{ actual} = 371.37$

Given: % Glycol = 30% Ethylene Glycol
 GPM = 80
 $EFT = 125^{\circ}F$
 $LFT = 115.5^{\circ}F$
 $EAT = 95^{\circ}F$
 Alt. = 2,000 ft

Notes:

1. The selection procedure is optimized for system performance while keeping fluid pressure drops below a reasonable maximum (less than 12 PSI). If calculated ΔP_{fluid} is greater than that desired, it is possible to make another selection on COLMAC's CoilPRO III software, using a "Hot Water/Sensible Cooling" coil, or have COLMAC's Factory Sales people assist in making another circuiting selection.
2. Flow Factors greater than 3.5 are not recommended, and are not represented in Figs. 10 thru 16.
3. See Table 5. for suggested inlet/outlet pipe sizing.

TABLE 5.

Gallons Per Minute	Suggested Inlet/Outlet Connection Size, MPT
2 - 6	1"
7 - 12	1 1/4"
13 - 20	1 1/2"
21 - 40	2"
41 - 80	2 1/2"
81 - 120	3"
121 - 260	4"
261 - 700	6"

* Based on mean head loss of 2.5ft / 100ft, ASHRAE Fundamentals Handbook, 1993

OPTIONAL FAN CONTROL

COLMAC offers FC Fan Cycling and MS Modulated Speed control packages to compliment the selection of any fluid cooler. Such controls may be used to maintain the desired Leaving Fluid Temperature regardless of operating conditions, or seasons.

FC fan cycling controls will stop rotation of one or more fans in incremental stages to maintain temperature.

MS controls will slow rotation of one or more fans to maintain temperature. On multiple fan models, a combination of Modulation and Cycling is used. If the fluid temperature falls below the point at which the Modulating fan(s) can maintain temperature, one or more additional fans will be shut off and the remaining Modulating fans will gain more speed until the desired fluid temperature is reached.

Note: Because MS controls affect motor winding temperature, please consult the Factory for application information and pricing.

FIGURE 5

FLUID HEAT FACTORS, FHF

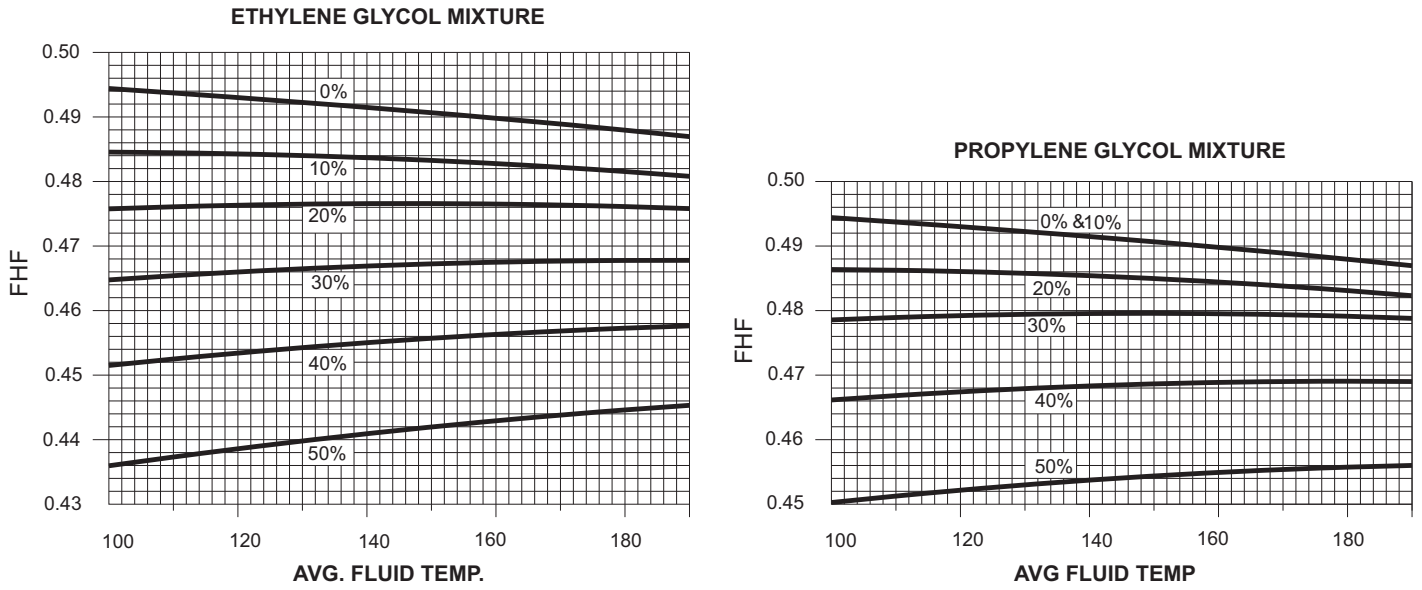
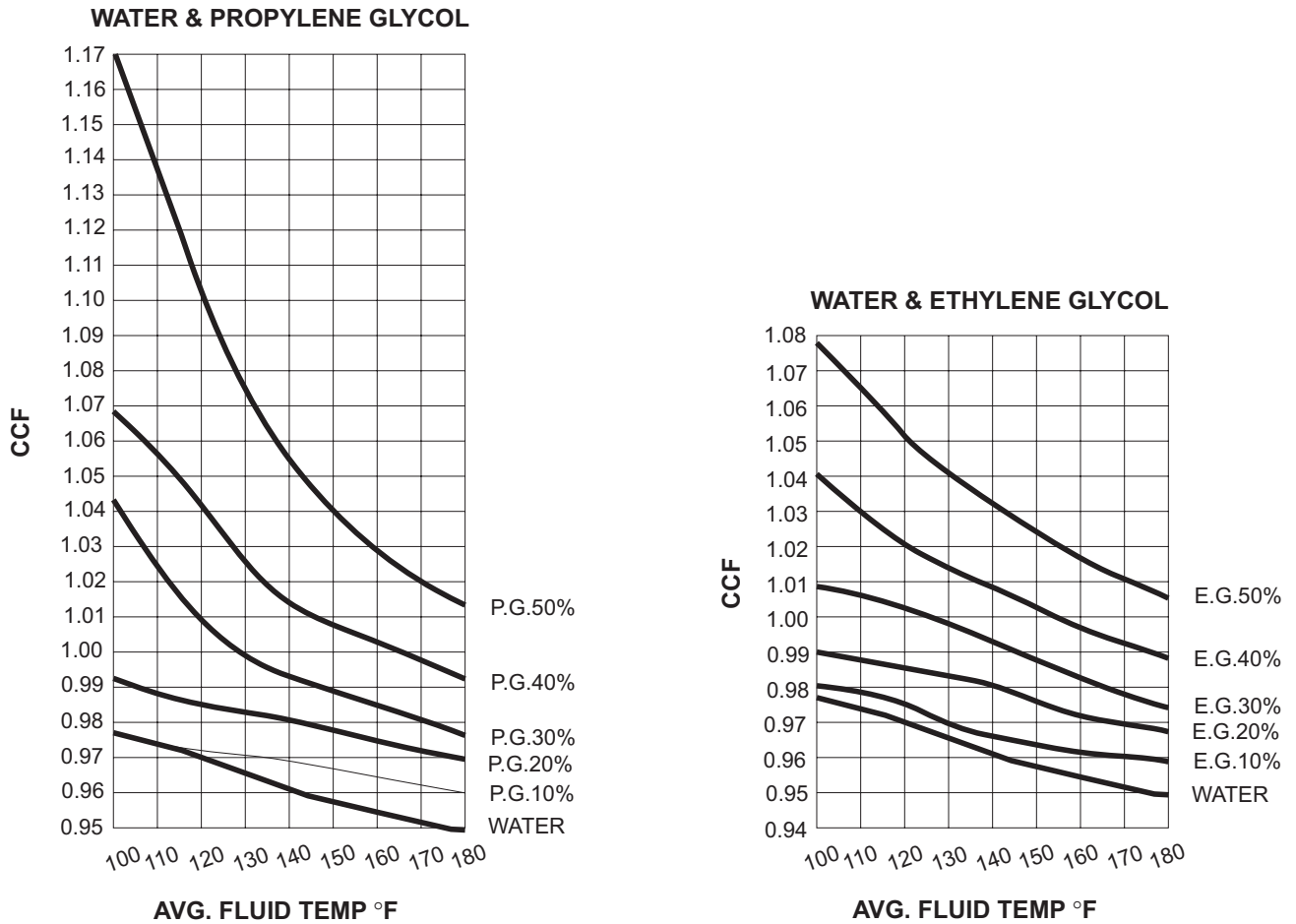
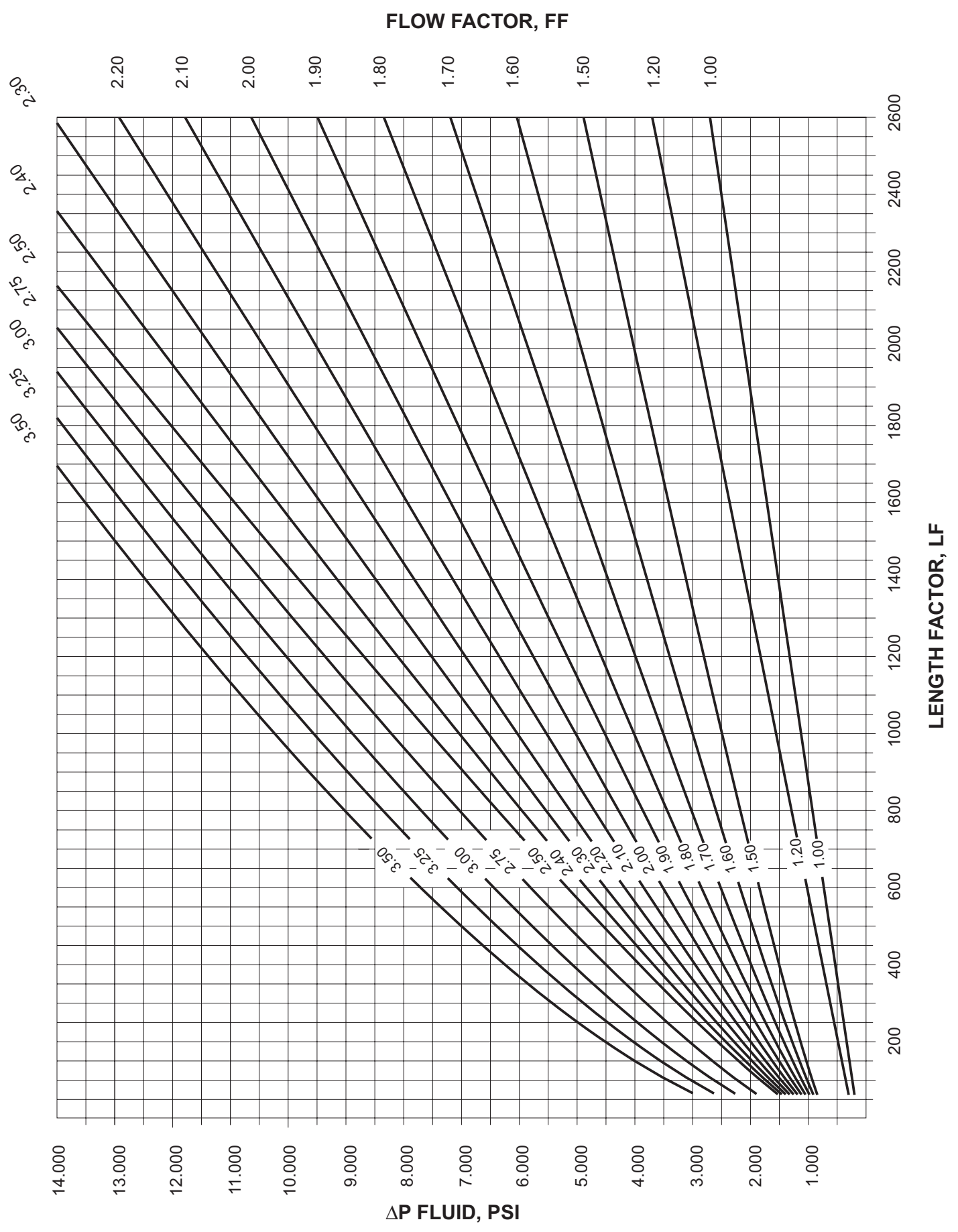

FIGURE 6

CAPACITY CORRECTION FACTORS, CCF



**FIGURE 7
FLUID PRESSURE DROP, ΔP FLUID**



**FIGURE 8
CORRECTION FACTOR, PDF
FLUID PRESSURE DROP**

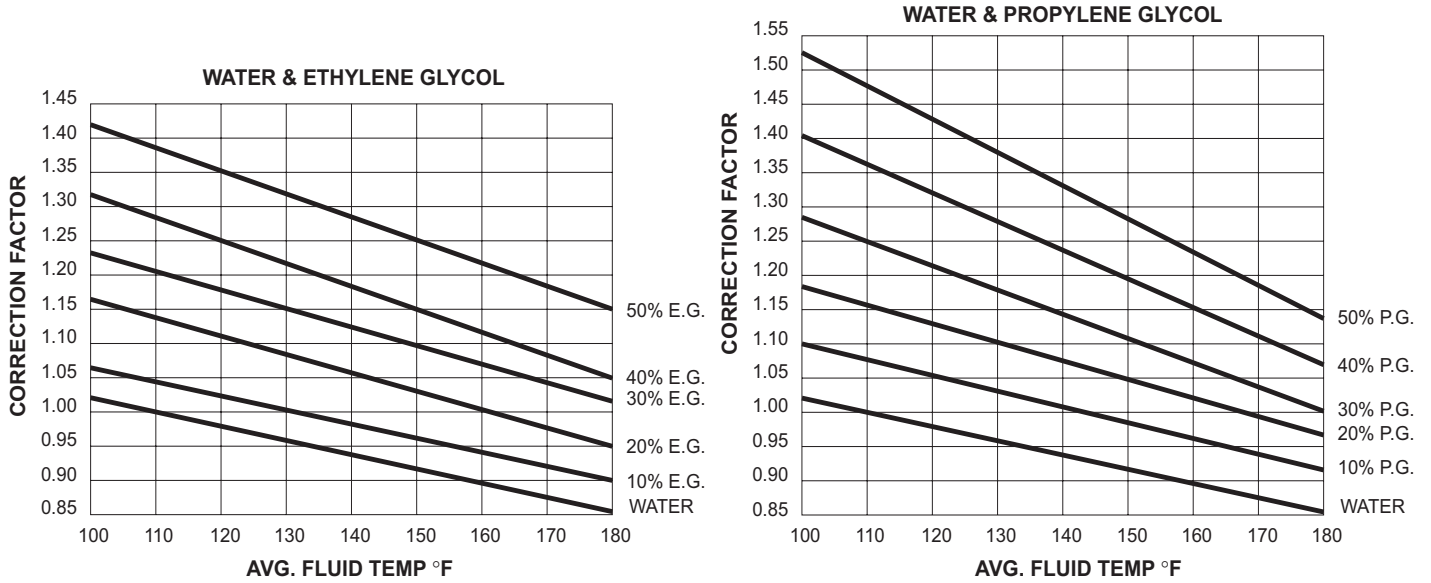

**FIGURE 9
ALTITUDE CORRECTION FACTOR**

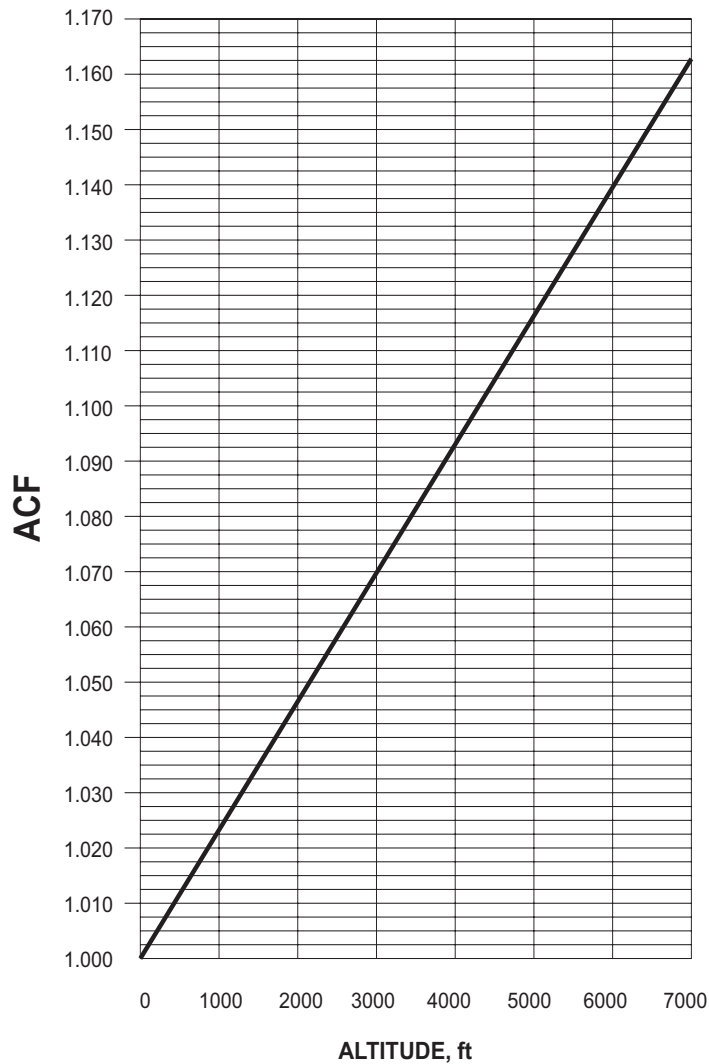
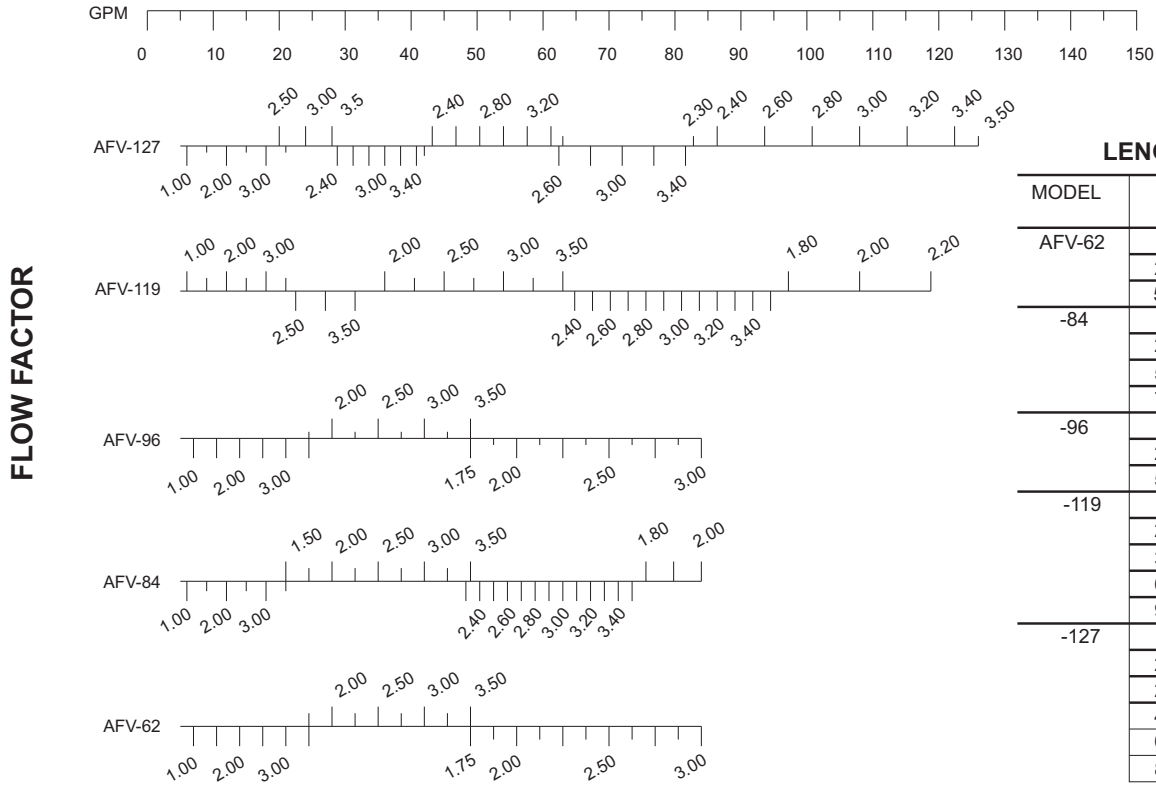

FIGURE 10 CAPACITY - 1 FAN FLUID COOLERS



LENGTH FACTOR

MODEL	GPM	LENGTH FACTOR
AFV-62	5 - 25	384
	26 - 49	192
	50 - 80	96
-84	5 - 21	672
	22 - 49	288
	50 - 74	192
-96	5 - 25	786
	26 - 49	384
	50 - 80	192
-119	5 - 21	972
	22 - 31	648
	32 - 63	324
	64 - 94	216
-127	5 - 21	1296
	22 - 28	972
	29 - 42	648
	43 - 64	432
	65 - 85	324
	86 - 120	216

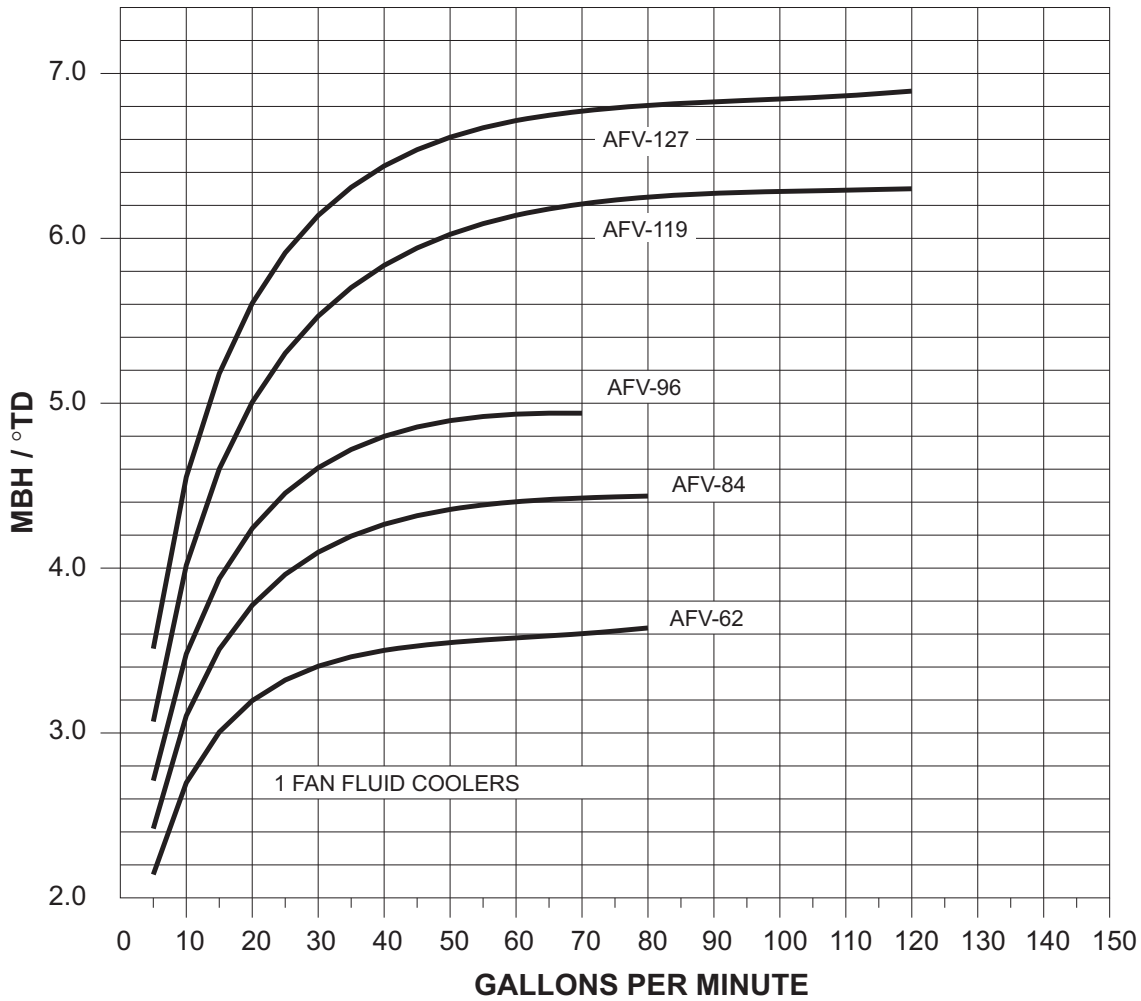
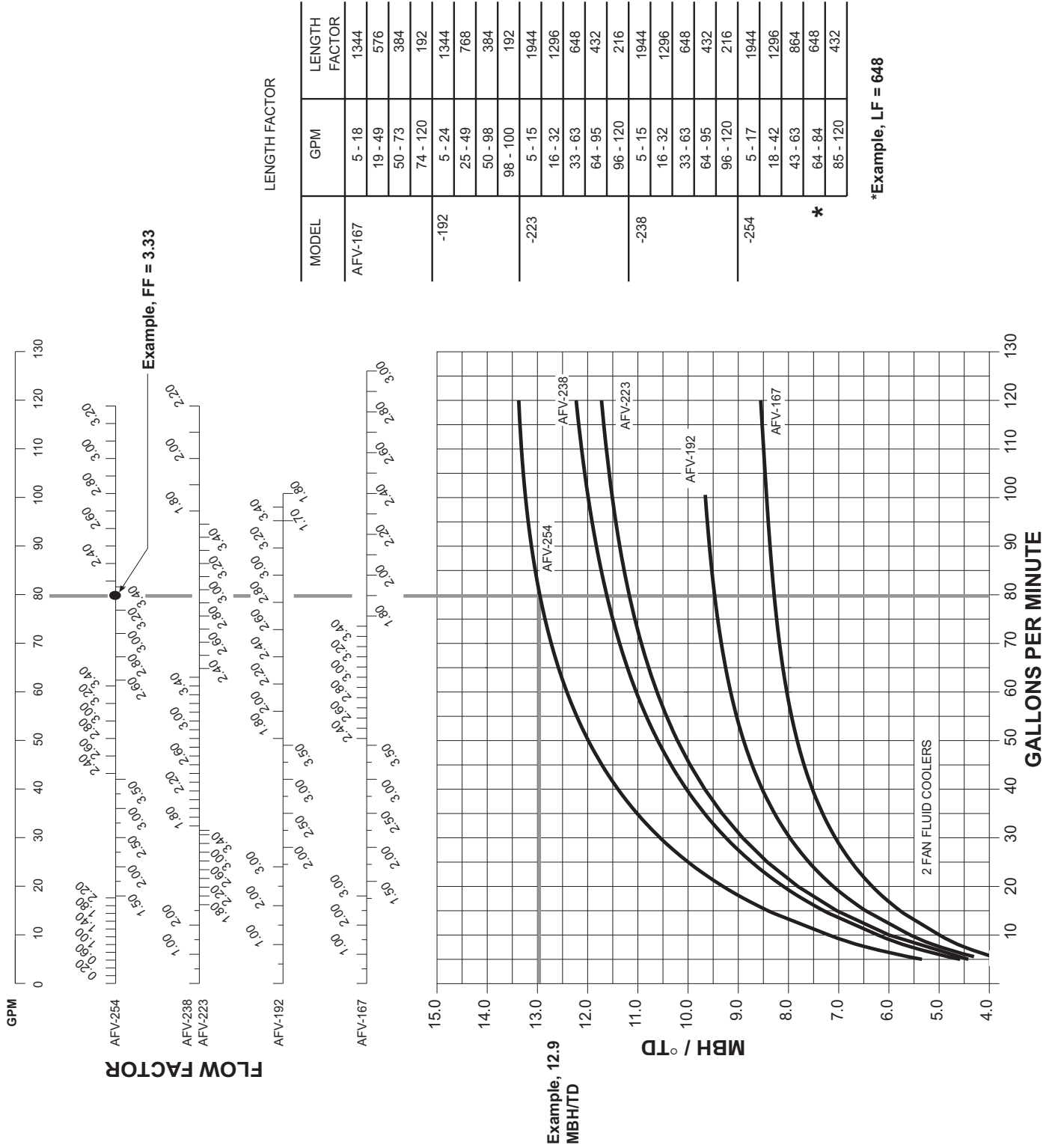
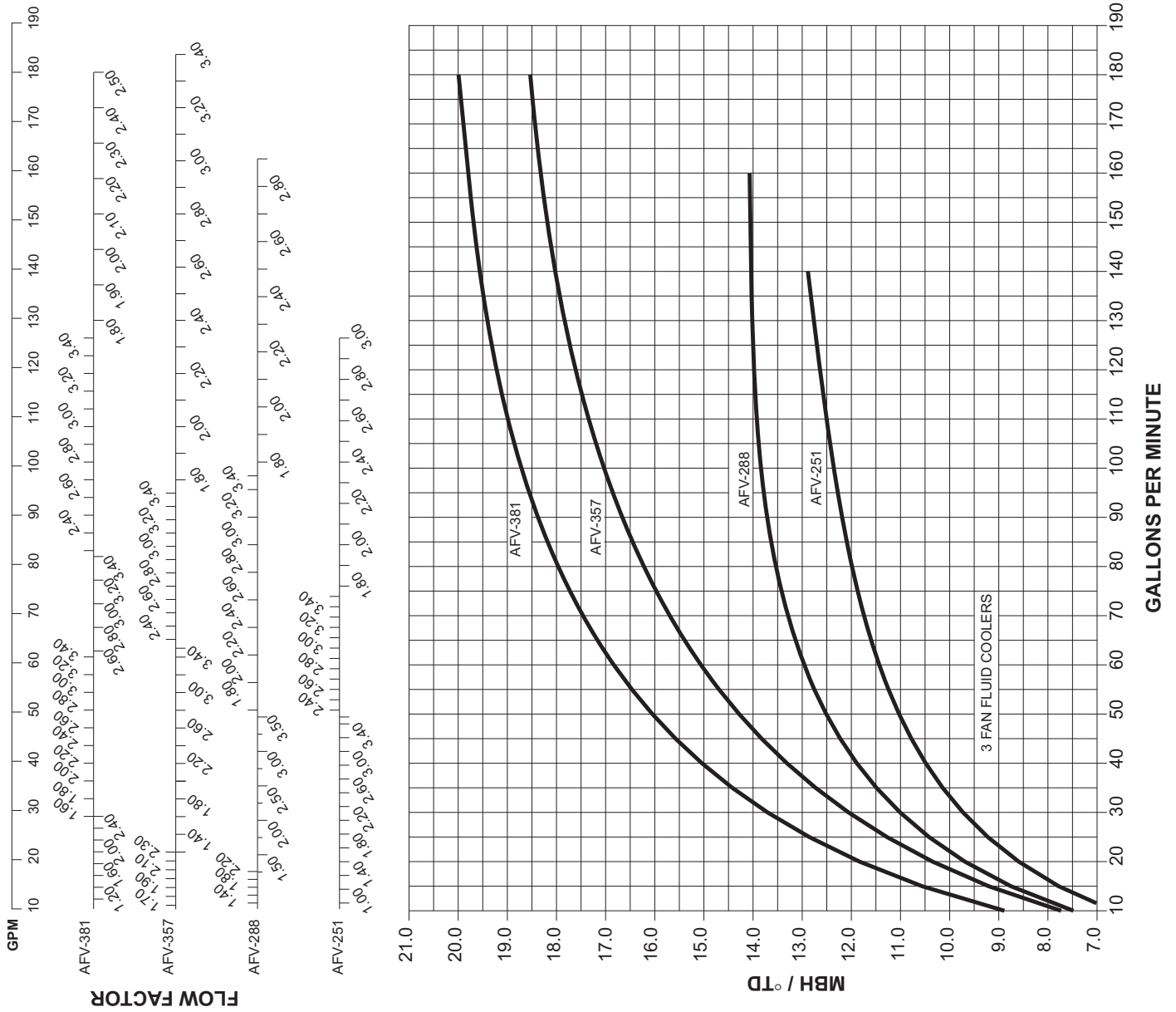

FIGURE 11 CAPACITY - 2 FAN FLUID COOLERS



*Example, LF = 648

FIGURE 12 CAPACITY - 3 FAN FLUID COOLERS



MODEL	GPM	LENGTH FACTOR
AFV-251	5 - 49	864
	50 - 73	576
	74 - 140	288
-288	5 - 18	2016
	19 - 49	1152
	50 - 98	576
-357	98 - 160	288
	5 - 21	1944
	22 - 63	972
-381	64 - 95	648
	96 - 180	324
	5 - 29	1944
	30 - 63	1296
	64 - 84	972
	85 - 126	648
	127-180	324

FIGURE 13 CAPACITY - 4 FAN FLUID COOLERS

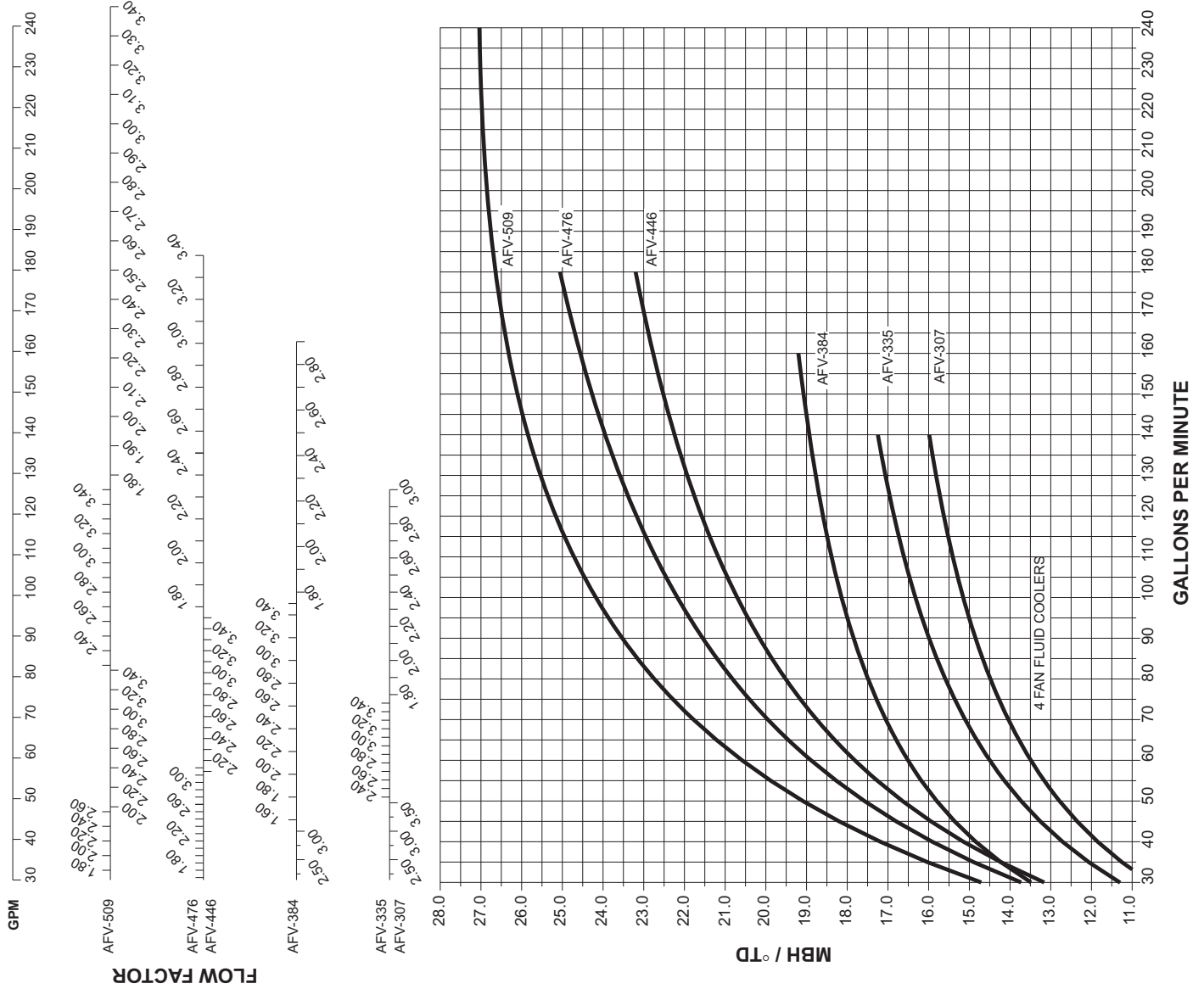

LENGTH FACTOR		MODEL	GPM	LENGTH FACTOR
AFV-307			5 - 49	1152
			50 - 73	768
			74 - 140	384
-384			5 - 42	1536
			43 - 98	768
			99 - 160	384
-446			5 - 57	1296
			58 - 94	864
-476			95 - 180	432
			5 - 47	1728
-509			48 - 81	1296
			82 - 126	864
			126-240	432

FIGURE 14 CAPACITY - 5 AND 6 FAN FLUID COOLERS

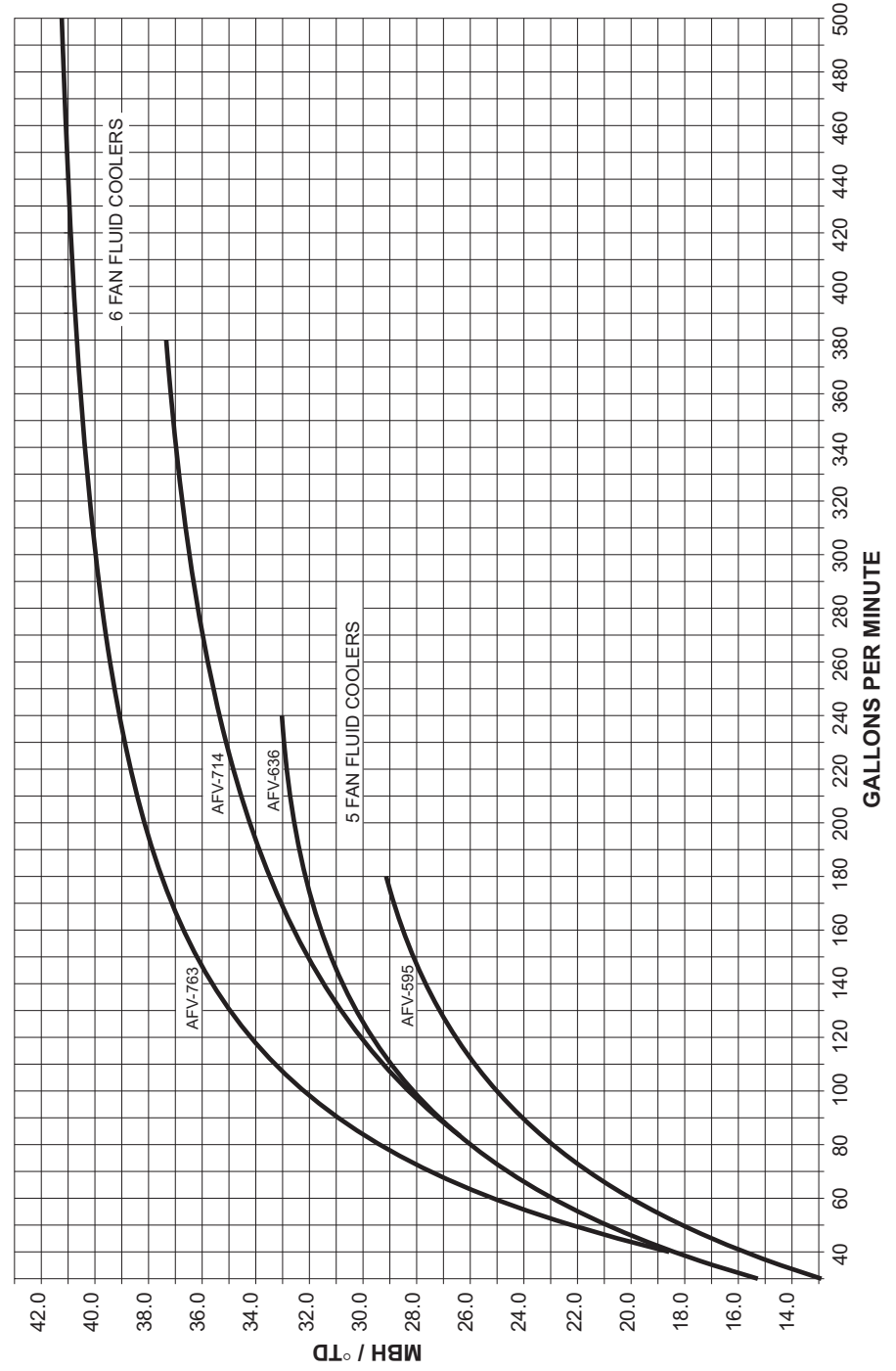
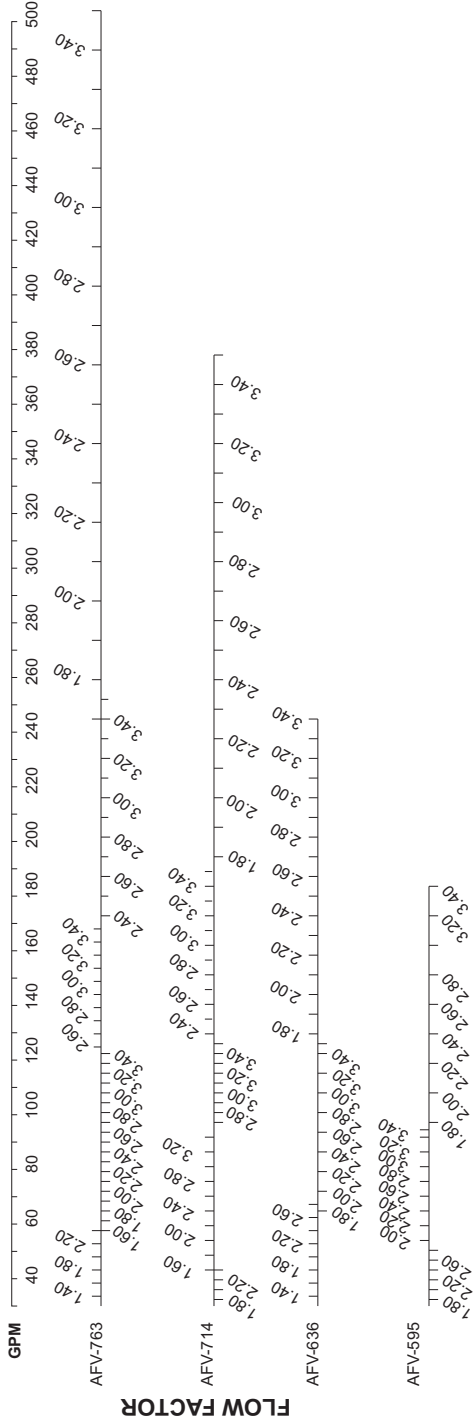

LENGTH FACTOR

MODEL	GPM	LENGTH FACTOR
AFV-595	30 - 51	1620
	52 - 94	1080
-636	95 - 180	540
	30 - 67	1620
-714	68 - 126	1080
	127-240	540
-763	30 - 43	1944
	44 - 92	1296
-763	93 - 126	972
	127-189	648
-763	190-380	324
	30 - 58	1944
-763	59 - 122	1296
	123-168	972
-763	169-252	648
	253-500	324

FIGURE 15 CAPACITY - 8 FAN FLUID COOLERS

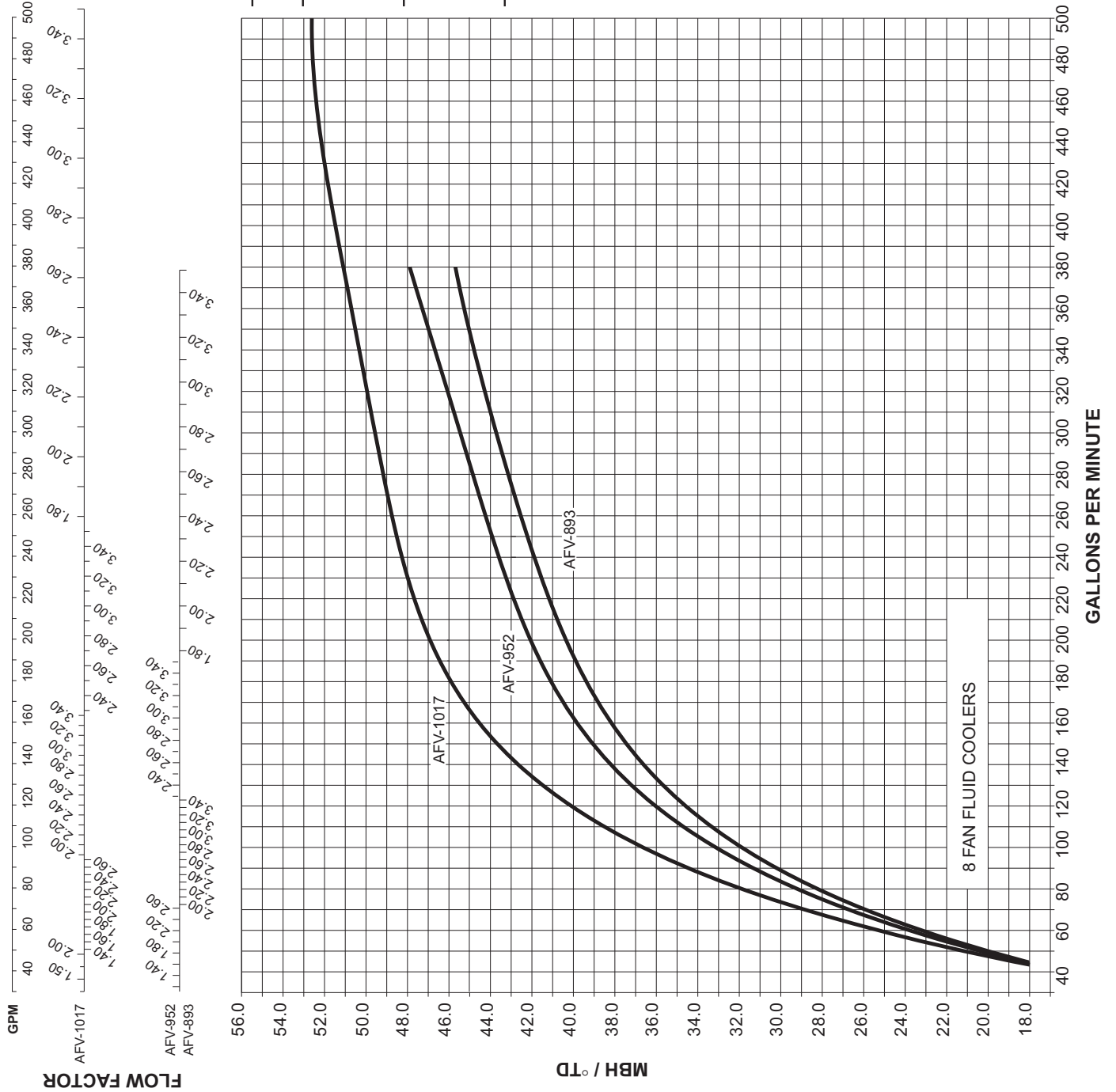

LENGTH FACTOR

MODEL	GPM	LENGTH FACTOR
AFV-893	30 - 70	1728
	71 - 122	1296
	123-189	864
-952	190-380	432
	30 - 70	1728
-1017	71 - 122	1296
	123-189	864
	190-380	432
	30 - 50	2592
	51 - 94	1728
	95 - 163	1296
	164-252	864
	253-500	432

FIGURE 16 CAPACITY - 10 FAN FLUID COOLERS

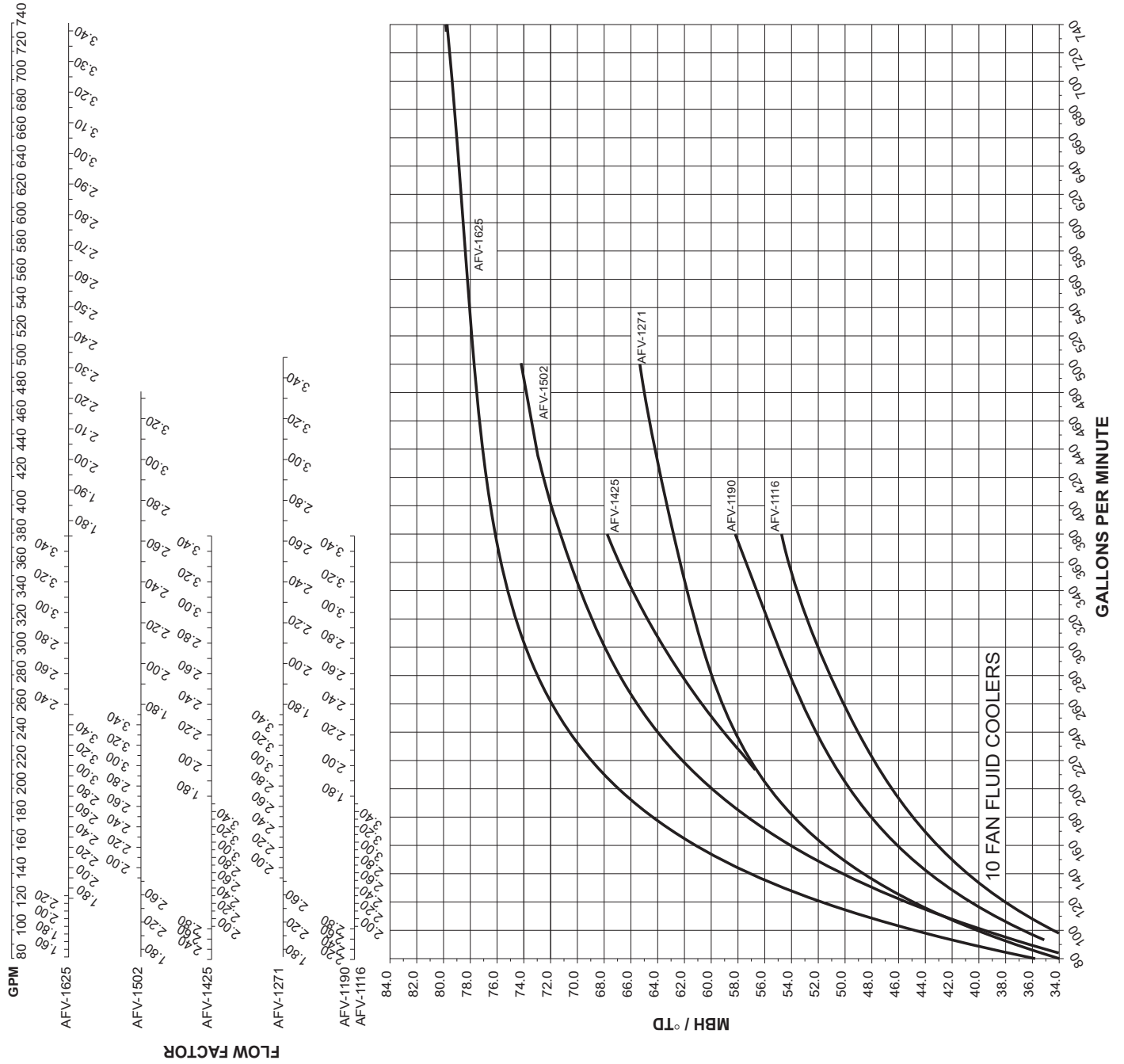

LENGTH FACTOR

MODEL	GPM	LENGTH FACTOR
AFV-1116	80-101	1620
	102-189	1080
	190-378	540
-1190	80-101	1620
	102-189	1080
	190-378	540
-1271	80-134	1620
	135-252	1080
	253-500	540
-1425	80-101	1620
	102-189	1080
	190-378	540
-1502	80-134	1620
	135-252	1080
	253-500	540
-1625	80-151	2160
	152-202	1620
	203-378	1080
	379-740	540



Other Quality Products From Colmac Coil



Heating and Cooling Coils



Heat Pipes for Heat Recovery



Dry Coolers for Glycol or Gas Cooling



Custom Evaporators & Baudelot Coolers



Air Cooled Condensers

CE(PED) Certification, ASME Sec. VIII, Canadian Registration Number, UL508, Canadian Standards Association



CRN



CSA

Visit www.colmaccoil.com for more information and resources:

Product Information

Product Literature

Sales Rep Locator

Sales Rep e-Library

Product Videos

North American Headquarters

Colmac Coil Manufacturing, Inc.
370 N. Lincoln St. | P.O. Box 571
Colville, WA 99114 | USA
+1.509.684.2595 | +1.800.845.6778

Midwest US Manufacturing

Colmac Coil Midwest
350 Baltimore Dr. | Paxton, IL 60957 | USA

"The Heat Transfer Experts"