

# STEAM HEATING COILS 1" OD TUBE

- Standard • Heavy Duty • Steam Distributing



*“The Heat Transfer Experts”*

# Table of Contents

General	1
Dimensions	2
Temperature Conversion Factor, Table 1	3
Altitude Conversion Factor, Table 2	3
Basic Formulas	3
Steam Coil Selection Example (using rating table)	3
Steam Coil Rating Table, Table 3	4
Air Pressure Drop, Table 4	4
Air Temperature Rise Correction Factor, Table 5	5
Properties of Saturated Steam, Table 6	5
Steam Coil Selection Example (using rating curves)	6
Steam Coil Rating Curves, Figure 1	7
Coil Weights	8
Application Recommendations	8

# COIL NOMENCLATURE

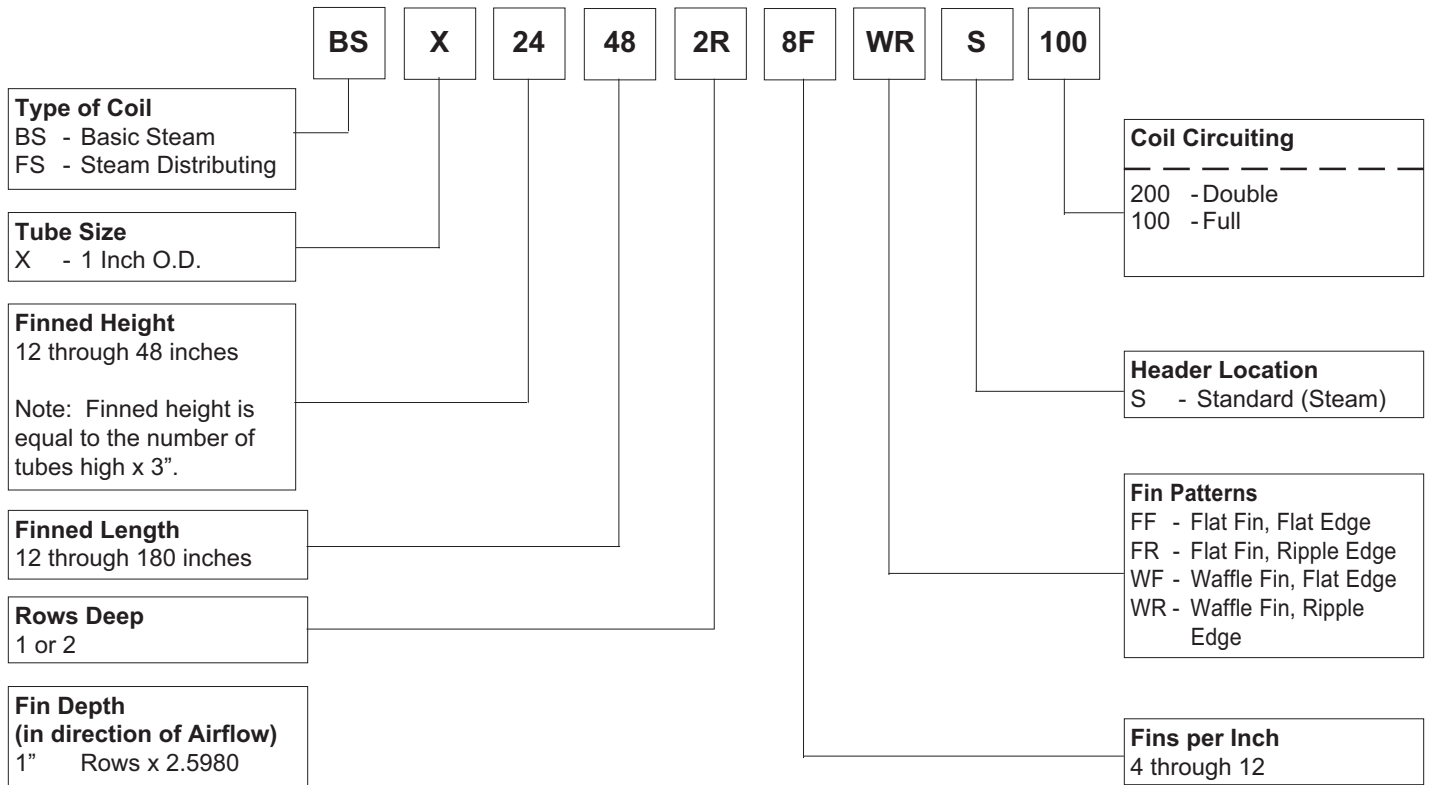

**FEATURES** — Colmac Type X Steam Coils are made with 1" O.D. diameter tubes. The tubes have 3 inch vertical spacing and 2.6" horizontal spacing.

**FINS** — The Fins are .010 or .016 plate type aluminum (copper & steel optional) die formed with a waffle surface and ripple edges. Each fin has formed self spacing collars completely covering the tube. The collars automatically and precisely space the fins in a uniform manner. Fin spacing of 4 to 12 fins per inch are available.

**TUBES** — The seamless 1" diameter copper tubes (cupro-nickel & brass available) are expanded into fin collars to form a rigid mechanical bond. Copper to copper joints are made with a high temperature brazing alloy, steel joints are made with a bronze brazing alloy. Inner tube is 5/8 x .018 copper.

**HEADERS** — One Row Type X Coils have inlet and out let headers made from heavy wall seamless copper tubing. Copper headers have extruded holes to provide a strong durable brazing joint, connectors are wrought copper as standard on one row coils. Two Row Type X Coils are made with heavy duty carbon steel headers and MPT connectors.

**CASING** — Galvanized steel (standard casings are designed for expansion and contraction. Coils are pitched in casing to provide positive condensate drainage. Stacking flanges are optional.

**TESTING** — The coil assembly is leak tested at 175 PSIG under water for copper headers & 350 PSIG for carbon steel headers, which is required for 2 row coils.

**BASIC STEAM** — Basic Steam coils are suitable for up to 150 PSIG steam pressure with .035 wall tubing. Supply and return connections are at opposite ends. When tubes are installed vertically the Basic Steam coil provides excellent freeze protection. With tubes horizontal, the Basic steam coil is used for re-heat applications.

**STEAM DISTRIBUTING** — Steam Distributing coils are rated up to 150 PSIG. 5/8" inner steam distributing tubes provide uniform steam distribution throughout the face of the coil. Distributing tube orifices are directionally jetted to sweep the condensate from the outer tube. Supply and return connections are on the same end.

# Dimensions For Steam Coils

## 1" Basic, Steam Heating Coil

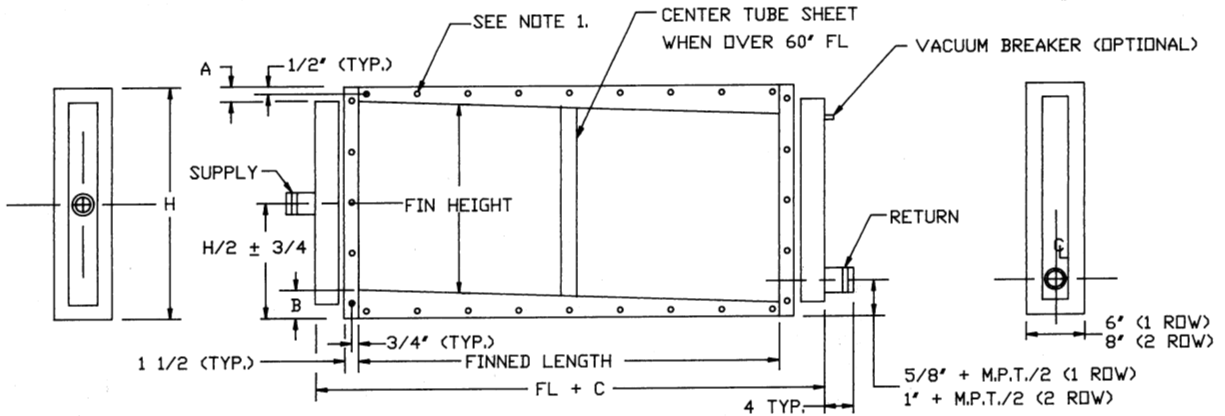

**NOTES:**

1. 5/16" DIA. HOLES ON 3' CTRS FROM CENTERLINE OF CASING.
2. COIL IS PITCHED IN CASING TOWARD RETURN END 1/4" PER FOOT OF FINNED LENGTH. A DIM PLUS B DIM PLUS FIN HEIGHT EQUALS H.

## 1" Steam Distributing Coil

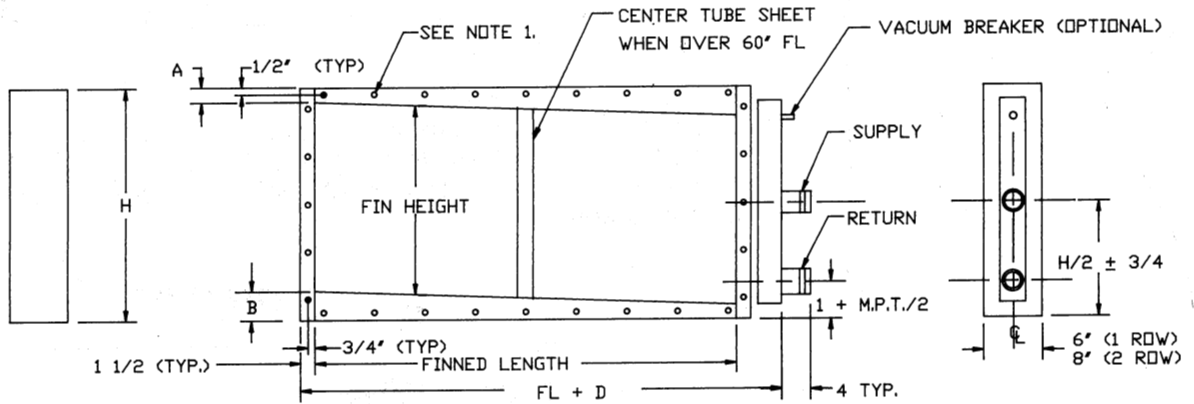

**NOTES:**

1. 5/16" DIA HOLES ON 3' CENTERS FROM CENTERLINE OF CASING.
2. COIL IS PITCHED IN CASING TOWARD RETURN END 1/4" PER FOOT OF FINNED LENGTH. A DIM PLUS B DIM PLUS FIN HEIGHT EQUALS H.

		M.P.T. CONNECTION SIZES																																															
B DIM. →		2 1/8						2 3/4						3 5/8						4 1/2																													
FINNED LENGTH →		12	15	18	21	24	27	30	33	36	39	42	45	48	51	54	57	60	63	66	69	72	75	78	81	84	87	90	93	96	99	102	105	108	111	114	117	120	123	126	129	132	135	138	144				
FINNED HEIGHT	TUBES HIGH																																																
12	4	1 ROW - 2" SUPPLY 1 1/2" RETURN C = 8 3/4" D = 7 1/4"																																															
15	5																																																
18	6																																																
21	7																																																
24	8	2 ROW - 2 1/2" SUPPLY 2" RETURN C = 11 1/2" D = 8 3/4"																																															
27	9																																																
30	10																																																
33	11																																																
36	12	1 ROW - 2 1/2" SUPPLY 2" RETURN C = 9 3/4" D = 8"																																															
39	13																																																
42	14																																																
45	15																																																
48	16	2 ROW - 3" SUPPLY 2 1/2" RETURN C = 11 1/2" D = 8 3/4"																																															
																										1 ROW - 2 1/2" SUPPLY 2 1/2" RETURN C = 10 1/4" D = 8"																							
		2 ROW - 3" SUPPLY 3" RETURN C = 11 1/2" D = 8 3/4"																																															

# Table 1

## Temperature Conversion Factor - (A)

Temp. °F	Factor (A)	(T) Temp. °F	Factor (A)
0	1.15	60	1.02
10	1.13	70	1.00
20	1.10	80	.98
30	1.08	90	.96
40	1.06	100	.95
50	1.04	110	.93

For Other Temperatures – (A) =  $\frac{530}{(T) + 460}$

# Table 2

## Altitude Conversion Factor – (B)

Alt. – Ft.	Factor (B)	Alt. – Ft.	Factor (B)
0	1.000	3000	.895
500	.982	4000	.864
1000	.965	5000	.832
1500	.947	6000	.802
2000	.930	7000	.771
2500	.921	8000	.743

Convert 8500 CFM at 40°F and 300 Ft. Altitude to SCFM

SCFM = 8500 x 1.06 x .985 = 8060 SCFM

Use 8060 SCFM when Capacity and Pressure Drop Tables are used.

### Formulae

Air Flow (CFM) = Cubic Feet Per Minute  
(SCFM) = CFM x Air Density Conversion Factors.

Note: Standard Air Has Density of .075 Lb./Cu. Ft.

Air Velocity (FPM) = CFM/Coil Face Area (Sq. Ft.)  
(SFPM) = SCFM/Coil Face Area (Sq. Ft.)

Air Temperature Rise (TR) = Leaving Dry Bulb (LDB)  
– Entering Dry Bulb (EDB)

Temperature Difference: = TD = Sat. Steam Temp.  
(Table 6) – Entering Dry Bulb (EDB)

Capacity: = Btuh = 1.085 x SCFM x TR  
Condensate Rate (LB/HR) = Btuh/Steam Latent Heat  
(BTU/LB)

Air Pressure Drop (APD) = Inches of Water

# EXAMPLE

## Selection Procedure Using Table Rating (Table 3):

(.010" Aluminum Waffle Fins, 1" x .049" Copper Tubes)

Given 6000 SCFM, 375,000 BTUH, 25 PSIG Steam,  
800 SFPM Face Velocity, 70°F Entering Dry Bulb.

### Example

#### 1. Determine Coil Face

$$\text{Velocity (SFPM)} = \frac{\text{SCFM}}{\text{Face Area Sq. Ft.}}$$

$$800 \text{ SFPM} = \frac{6000 \times 1.00}{\text{Sq. Ft.}}$$

$$\text{Sq. Ft.} = 7.50$$

Select: 15 x 72 or  
18 x 60 or  
30 x 36

#### 2. Calculate TR

$$\text{TR} = \frac{\text{Btuh}}{1.085 \times \text{SCFM}}$$

$$= \frac{375,000}{1.085 \times 6000}$$

$$= 57.6^\circ\text{F}$$

#### 3. Convert to Standard Rating Conditions of 5 PSIG Steam, 0°F Entering Dry Bulb

Use Air Temperature Correction Factor (Table 5)  
to Convert to Standard Conditions:

$$\text{TR @ 5 PSIG, } 0^\circ\text{EDB} = \frac{57.6}{.876}$$

$$= 65.8^\circ\text{F}$$

#### 4. Select Row and Fin For Coil

Using Table 3 at 65.8°F, 800 SFPM

208 (2 Row, 8 FPI) will handle the load

**Table 3**

<b>AIR TEMPERATURE RISE AT 5 PSIG, 0° EDB</b>						
<small>(.010" Aluminum Waffle Fins, 1" x .035" Copper Tubes)</small>						
Face Velocity, SFPM						
<b>ROW</b>						
<b>FIN</b>	<b>200</b>	<b>400</b>	<b>600</b>	<b>800</b>	<b>1000</b>	<b>1200</b>
104	55.4	37.5	29.6	25.0	21.9	19.6
106	75.9	51.0	39.8	33.3	28.9	25.7
108	93.6	62.4	48.4	40.1	34.6	30.6
110	111.1	74.8	58.0	48.0	41.3	36.5
112	126.7	86.2	66.9	55.3	47.5	41.9
208	148.7	107.7	86.5	73.2	64.0	57.1
210	167.8	125.0	101.1	85.9	75.2	67.1
212	182.7	139.7	114.1	97.2	85.1	76.1
408	200.0	164.3	140.0	122.8	109.9	99.9
608	217.7	194.1	173.2	156.4	142.9	131.9

To determine capacity (Btuh) per sq. ft. of face area, multiply SFPM X 1.085 X Air Temp. Rise.

To determine air temperature rise and capacity for other steam pressures and entering air temperatures, multiply rise and capacity at 5 PSIG and 0 °F EDB by the appropriate temperature correction factor from Table 5.

**Table 4**

<b>AIR PRESSURE DROP, INCHES OF WATER</b>						
<small>(.010" Aluminum Waffle Fins, 1" x .035" Copper Tubes)</small>						
Face Velocity, SFPM						
<b>ROW</b>						
<b>FIN</b>	<b>200</b>	<b>400</b>	<b>600</b>	<b>800</b>	<b>1000</b>	<b>1200</b>
104	.008	.022	.040	.061	.085	.111
106	.012	.033	.058	.087	.120	.155
108	.016	.043	.075	.113	.154	.199
110	.023	.061	.108	.162	.223	.289
112	.030	.079	.140	.211	.293	.379
204	.016	.044	.080	.122	.170	.222
208	.032	.086	.150	.226	.308	.398
210	.046	.122	.216	.324	.446	.578
212	.060	.158	.280	.422	.586	.758
408	.064	.172	.300	.452	.616	.796
608	.096	.258	.450	.678	.924	1.194

**Table 5**

**Air Temperature Rise Correction Factor**  
**Steam Pressure, Pounds Per Square Inch Gauge**

Entering Air Temp °F	0	2	5	10	15	20	25	30	40	50	60	80	100
-40	1.110	1.139	1.177	1.231	1.276	1.316	1.352	1.383	1.439	1.488	1.530	1.603	1.665
-30	1.066	1.095	1.187	1.232	1.187	1.272	1.307	1.339	1.395	1.444	1.486	1.559	1.621
-20	1.022	1.051	1.089	1.143	1.188	1.228	1.263	1.295	1.351	1.400	1.442	1.515	1.577
-10	0.978	1.007	1.044	1.099	1.144	1.184	1.219	1.251	1.307	1.356	1.398	1.471	1.533
0	0.934	0.963	1.000	1.055	1.100	1.140	1.175	1.207	1.263	1.311	1.354	1.427	1.489
10	0.890	0.919	0.956	1.011	1.056	1.096	1.131	1.163	1.219	1.267	1.310	1.383	1.444
20	0.846	0.874	0.912	0.967	1.012	1.052	1.087	1.119	1.175	1.223	1.266	1.339	1.400
30	0.802	0.830	0.868	0.922	0.968	1.008	1.043	1.075	1.131	1.179	1.222	1.295	1.356
40	0.758	0.786	0.824	0.878	0.924	0.964	0.999	1.031	1.087	1.135	1.178	1.251	1.312
50	0.714	0.742	0.780	0.834	0.880	0.920	0.955	0.987	1.043	1.091	1.133	1.207	1.268
60	0.670	0.698	0.736	0.790	0.836	0.876	0.911	0.943	0.999	1.047	1.089	1.163	1.224
70	0.626	0.654	0.692	0.746	0.792	0.832	0.876	0.899	0.955	1.003	1.045	1.119	1.180
80	0.581	0.610	0.648	0.702	0.748	0.788	0.823	0.855	0.911	0.959	1.001	1.074	1.136
90	0.537	0.566	0.604	0.658	0.704	0.744	0.779	0.811	0.867	0.915	0.957	1.030	1.092
100	0.493	0.522	0.560	0.614	0.659	0.700	0.735	0.767	0.822	0.871	0.913	0.986	1.048
110	0.449	0.478	0.516	0.570	0.615	0.656	0.691	0.722	0.778	0.827	0.869	0.942	1.004
120	0.405	0.434	0.472	0.526	0.571	0.611	0.647	0.678	0.734	0.783	0.825	0.898	0.960
130	0.361	0.390	0.428	0.482	0.527	0.567	0.603	0.634	0.690	0.739	0.781	0.854	0.916
140	0.317	0.346	0.384	0.438	0.483	0.523	0.559	0.590	0.646	0.695	0.737	0.810	0.872
150	0.273	0.302	0.340	0.394	0.439	0.479	0.515	0.546	0.602	0.651	0.693	0.766	0.828

Correction Factor = (Steam Temperature – Entering Air Temperature + 227.1)

**Table 6**

**Properties Of Steam**

PSIG	Sat. Temp. °F	Latent Heat (Btu/ lbs.)
2	218.0	966.1
5	227.1	960.6
10	239.4	952.6
15	249.7	945.7
20	258.8	939.6
25	266.8	934.0
30	274.0	929.0
40	286.7	919.9
50	297.7	911.8
60	307.3	904.7
70	316.0	898.0
80	323.9	891.9
90	331.2	886.2
100	337.9	880.8

# EXAMPLE

## Selection Procedure Using Curves (Figure 1):

(.010" Aluminum Waffle Fins, 1" x .035" Copper Tubes)

Given 12,000 CFM, 40°F Entering Dry Bulb, 130°F Leaving Dry Bulb, 10 PSIG Steam, 36" x 72" Duct Size.

### Procedure

### Example

- 1. Calculate Coil**  
Face Velocity, SFPM  
Note: Use A and B Factors  
From Table 1,2.

$$\begin{aligned} \text{SFPM} &= \frac{\text{SCFM}}{\text{Sq. Ft.}} \\ &= \frac{12,000 \times 1.06}{3.0 \times 6.0} \end{aligned}$$

$$\text{SFPM} = 706.7$$

---

- 2. Calculate**  $\frac{\text{TR}}{\text{TD}}$

$$\begin{aligned} \frac{\text{TR}}{\text{TD}} &= \frac{\text{Air Temp. Rise}}{\text{Steam Temp. -EDB}} \\ &= \frac{130-40}{239.4-40} \end{aligned}$$

$$= .451$$

---

- 3. Select Row-Fin For Coil**

Enter Figure 1 at 706.7 SFPM,  
select Row/Fin having TR/TD Factor  
equal to or greater than .451.  
A 212 (2 Row/12 FPI) will handle the load.



# Capacity Curves

(.010" Aluminum Waffle Fins, 1" x .035" Copper Tubes)

**FIGURE 1**

TYPE BS-X & FS-X  
Col Effectiveness vs SFPM  
REV. A

EXAMPLE:  
106 = 1 Row, 6 FPI

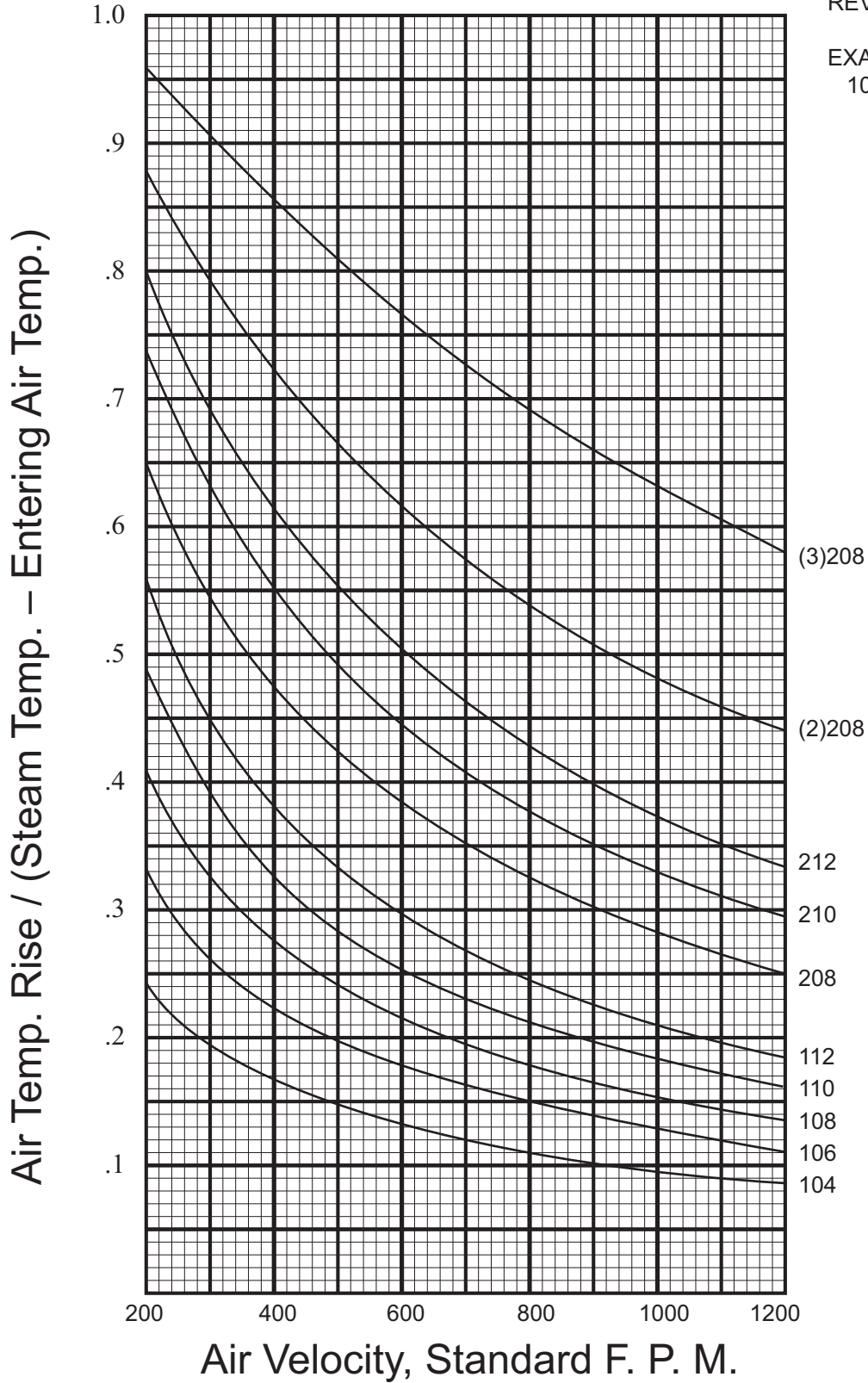

REF  
COLMAC DWG.  
No. B20415

# Coil Weights – Dry Pounds

(.010" Aluminum Waffle Fins, 1" x .035" Copper Tubes)

## Fin Length (Inches)

Fin Height	12	18	24	30	36	42	48	54	60	66	72	78	84	90	96	108	120	132	144
12	27	33	39	45	52	58	64	70	76	82	88	94	101	107	113	125	138	150	162
18	36	44	52	60	68	76	84	92	100	108	116	124	132	140	148	164	180	196	212
24	45	55	65	75	85	94	104	114	124	134	144	153	163	173	183	202	222	242	261
30	55	66	78	89	101	113	125	136	148	159	171	183	195	206	218	241	264	288	311
36	64	77	91	104	118	131	145	158	172	185	199	212	226	240	253	280	307	334	361
42	73	88	104	119	134	150	165	180	196	211	226	242	257	273	288	318	349	380	410
48	82	99	116	134	151	168	185	202	220	237	254	271	288	305	323	356	392	426	460

**NOTES:**

1. Weights Based On 10 FPI Coils, Variance For 6, 8, and 12 FPI is Less Than 5% Of Listed Weight.

## Application Recommendations

- Install and pipe coils in accordance with standard industry practice and applicable national and local codes.
- Support all piping independent of coil.
- Provide swing joints to absorb thermal expansion and contraction of coil tubes.
- Make return line piping to drop leg same size as coil outlet (do not bush).
- Install drip trap in steam mains ahead of coil.
- Trap each coil independently and locate trap a minimum of 12 inches below return connection of coil.
- In order to handle the high condensate load during initial start up period, traps should be sized 2-3 times the rated condensate load of the coil(s).
- Coils should be provided with a continuous method of eliminating non condensible gases, either by automatic or continuous vents.
- Minimum operating pressure recommended is 5 psig.
- Coils must be installed so tubes are pitched at least 1/4 inch per foot toward return header.
- When using automatic control valves, the condensate must not be lifted into overhead return mains, or drained into return mains in which a pressure is maintained.
- Do not oversize control valves, whether automatic or manually operated. Control valves should be selected from the actual steam consumption and not from the size of the coil supply connections.
- Check valves should only be installed in horizontal lines. Only 15° check valves should be used since they open under a lower head of water.
- When starting up a steam coil, the steam should be admitted at least 15 minutes before the fans are started or fresh air dampers are opened with outside air entering at 40°F or lower.
- Install a vacuum breaker at the coil outlet to prevent back filling of coil with condensate during periods of low load or at shut-down.



## Other Quality Products From Colmac Coil



Heating and Cooling Coils



Heat Pipes for Heat Recovery



Dry Coolers for Glycol or Gas Cooling

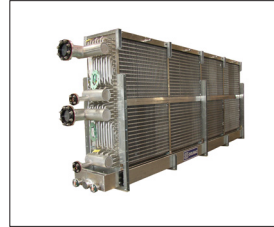

Custom Evaporators & Baudelot Coolers



Air Cooled Condensers

CE(PED) Certification, ASME Sec. VIII, Canadian Registration Number, UL508, Canadian Standards Association



CRN



CSA

Visit [www.colmaccoil.com](http://www.colmaccoil.com) for more information and resources:

- Product Information
- Product Literature
- Sales Rep Locator
- Sales Rep e-Library
- Product Videos

### North American Headquarters

Colmac Coil Manufacturing, Inc.  
370 N. Lincoln St. | P.O. Box 571  
Colville, WA 99114 | USA  
+1.509.684.2595 | +1.800.845.6778

### Midwest US Manufacturing

Colmac Coil Midwest  
350 Baltimore Dr. | Paxton, IL 60957 | USA

*"The Heat Transfer Experts"*