

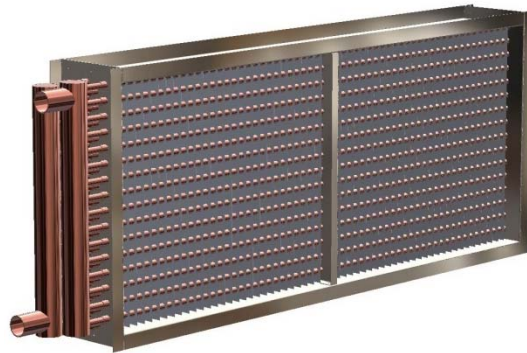

When you want Quality, specify COLMAC!



**Installation, Operation,
and Maintenance**
ENG00013633 Rev A
Water/Fluid Coil

Contents

1. NOMENCLATURE	0
2. INSTALLATION	0
3. PIPING	1
4. OPERATION	3
5. MAINTENANCE	4

1. NOMENCLATURE

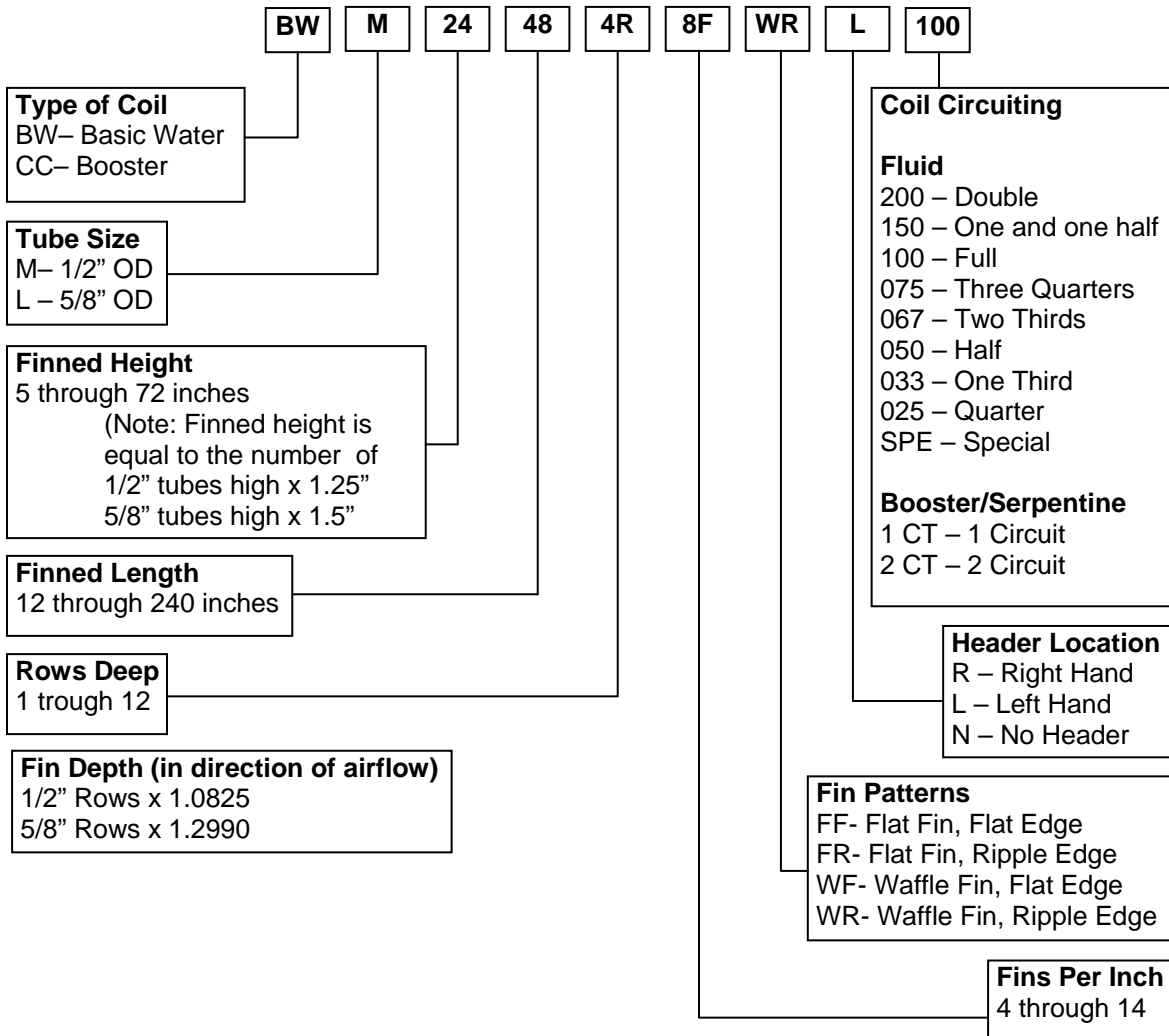

2. INSTALLATION

2.1. Inspection

2.1.1. Damage or Shortage – Upon receipt of equipment, inspect for shortage and damage. Any shortage or damage found during initial inspection should be noted on delivery receipt; this action notifies the carrier that you intend to file a claim. If any shortage or damage is discovered after unpacking the unit, call the deliverer for a concealed damage or shortage inspection. The inspector will need related paperwork, delivery receipt, and any information indicating his liability for the damage.

2.2. General

2.2.1. After carefully removing the coil from crating, repair any minor damage to fins using a fin comb with the appropriate spacing.

- 2.2.2. It is recommended that coils be cleaned prior to installation using a commercially available coil cleaner.
- 2.2.3. Check coil hand to insure the connections match system piping. Hand of connection is determined by the supply connection side when viewing the coil, looking in the direction of airflow (See Figure 1 below).
- 2.2.4. Type BW coils should always be piped with the water/fluid supply connection on the air leaving side of the coil. This will produce counterflow heat exchange and maximize heat transfer (See Figure 1 below).

FIGURE 1
BW COIL CONNECTIONS

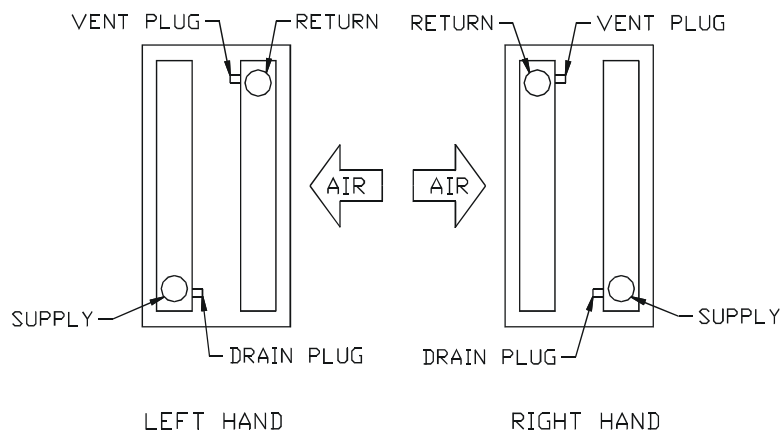

2.3. Mounting

- 2.3.1. Install type BW coils with tubes horizontal and level. This will allow for the most effective venting and draining of coils on startup and shutdown.
- 2.3.2. Type BW coils used with hot water/fluid for air heating may be designed for use with either horizontal or vertical airflow provided the coil tubes are level. Installation of type BW coils with tubes oriented vertically is not recommended.
- 2.3.3. Type BW coils used with chilled water/fluid for cooling and dehumidifying air should be designed for horizontal airflow with tubes horizontal and level. Draining of condensate from the fins is most easily accomplished with this arrangement. Vertical airflow is not recommended for type BW chilled water/fluid coils which cool and dehumidify air.

3. PIPING

- 3.1. Water piping must be done in accordance with all applicable national and local codes.
- 3.2. All piping must be self-supporting and flexible enough to allow for thermal expansion and contraction. The use of flexible connections and/or swing joints is recommended, particularly in hot water systems.

- 3.3. Vent each coil at its highest location to insure the exit of gases and to promote proper drainage.
- 3.4. Piping should be the same size as the inlet and outlet connections.
- 3.5. To make leak free threaded pipe connections, use only good quality fittings with tapered threads. Use of liquid Teflon type pipe joint compound is recommended.
- 3.6. To allow for servicing, manual service valves should be installed to isolate the coil.
- 3.7. Pipe water coils according to Figures 2 and 3:

FIGURE 2
BW COIL PIPING
HORIZONTAL AIRFLOW
(HOT WATER OR CHILLED WATER/GLYCOL)

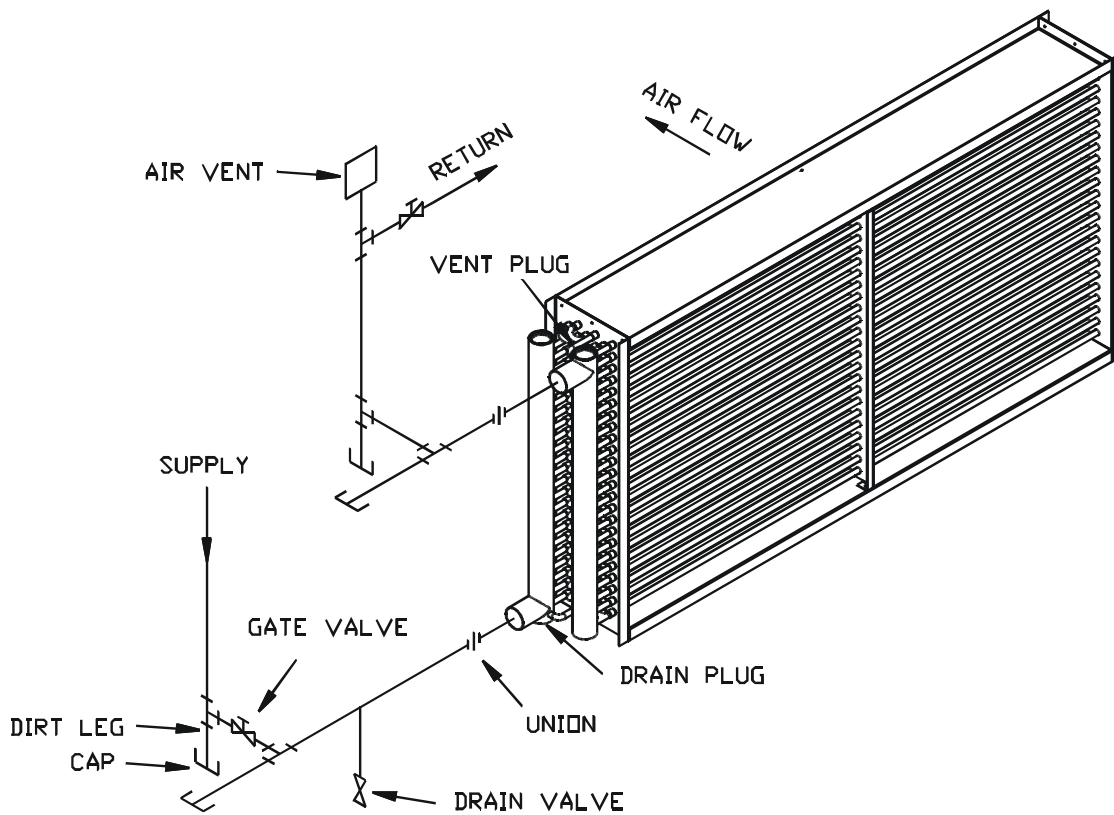
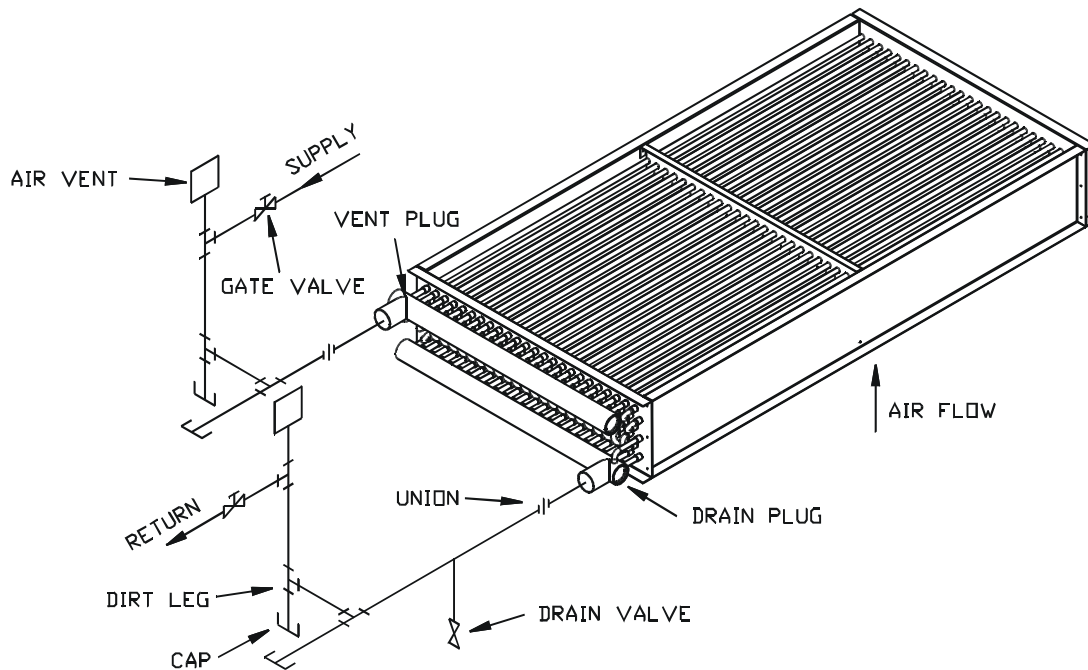

FIGURE 3
 BW COIL PIPING
 VERTICAL AIRFLOW
 (HOT WATER/AIR HEATING ONLY)



4. OPERATION

4.1. Startup

- 4.1.1. Once the coil is installed, it should be pressurized to 100 psig with dry nitrogen. The coil should be held at this pressure for 15 minutes to insure there are no leaks.
- 4.1.2. Open air vents, close drains, fill coil with water, and close vents. Perform a hydrostatic leak test on all piping joints to insure there are no leaks. Drain and discard water charge.
- 4.1.3. After the coil and piping are leak tested, open all air vents so that air is eliminated from the coil tubes and headers. Verify that all vents and drains discharge a stream of water/fluid and are not blocked.
- 4.1.4. Fill the coil with water/fluid then close all vents and drains.
- 4.1.5. During initial startup, tighten all bolted connections once the system stabilizes at operating temperature.
- 4.1.6. Keep operating pressures and velocities at or below the design limit.
- 4.1.7. Airflow should not vary by more than 20 % anywhere on the coil surface.
- 4.1.8. Drain coils to prevent corrosion during shutdown.

- 4.1.9. In glycol based systems, always use inhibited glycols. Use of uninhibited glycols can result in formicary corrosion in copper tubes.
- 4.1.10. In chilled water systems, use the following procedure to effectively prevent freeze damage to water coils after shutdown during periods of cold weather:
 - 4.2. **Freeze Protection**- Freezing can cause severe damage to water coils and it is recommended that the following preventative procedure be performed during shutdown to prevent such damage.
 - 4.2.1. Drain water from coil.
 - 4.2.2. Blow out remaining water droplets with compressed air.
 - 4.2.3. Completely fill coil with anti-freeze solution of appropriate concentration for the lowest temperatures anticipated.
 - 4.2.4. Drain anti-freeze solution from coil and replace drains and vents.
 - 4.2.5. The recovered anti-freeze solution can be used to perform this procedure on other coils.

5. MAINTENANCE

- 5.1. To insure proper coil performance, finned surfaces and tubes should be cleaned on a regular basis using a commercially available coil cleaner. Clean finned surface from the air leaving side.
- 5.2. Inspect coil and piping for corrosion and leaks on a regular basis.
- 5.3. Keep circulating fluid free of sediment and corrosive elements. The use of fluid filters is recommended.
- 5.4. If automatic air vents are not utilized, periodic venting of the coil is recommended to remove accumulated air. Caution should be exercised to avoid injury. Contact with venting high pressure and/or high temperature fluids can cause serious personal injury.
- 5.5. Inspect and tighten all bolted connections on a regular basis.



Colmac reserves the right to change product design and specifications without notice.

For more information on Colmac products call us at 1-800-845-6779 or visit us online at:

WWW.COLMACCOIL.COM

