

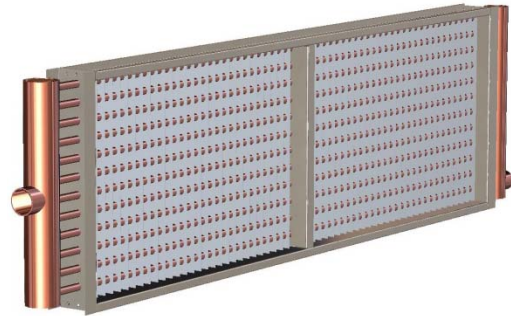

When you want Quality, specify COLMAC!

**Installation, Operation,
and Maintenance**
ENG00013573 Rev A
Steam Heating Coils



Contents

1. NOMENCLATURE	1
2. INSTALLATION	1
3. GENERAL PIPING	1
4. PREHEAT SYSTEMS PIPING	2
5. REHEAT SYSTEMS PIPING	5
6. PROCESS HEATING PIPING	8
7. STARTUP	10
8. OPERATION	10
9. MAINTENANCE	10

1. NOMENCLATURE

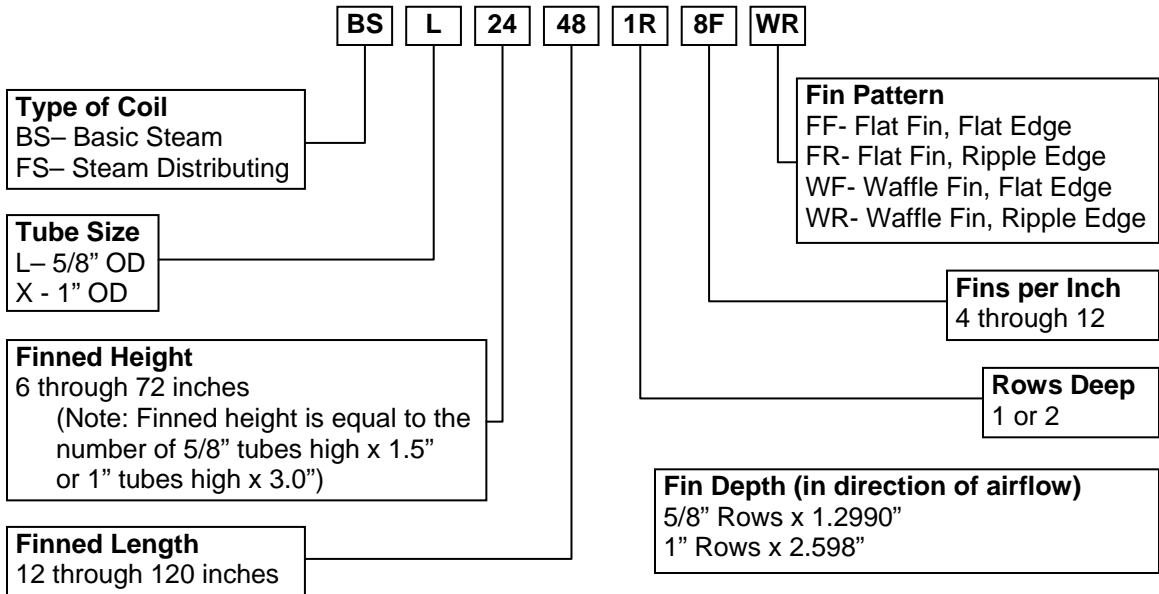

2. INSTALLATION

- 2.1. Inspection – Upon receipt of equipment, inspect for shortage and damage. Any shortage or damage found during initial inspection should be noted on delivery receipt; this action notifies the carrier that you intend to file a claim. If any shortage or damage is discovered after unpacking the unit, call the deliverer for a concealed damage or shortage inspection. The inspector will need related paperwork, delivery receipt, and any information indicating his liability for the damage.
- 2.2. Steam coils must be installed in a way that promotes condensate drainage. This will aid in preventing destructive water hammer, freezing, and the buildup of corrosive elements within the tubes.
- 2.3. Mounting- Steam coils must be mounted so that tubes are pitched ¼" per foot toward the condensate return. Colmac can provide coil casings with tubes correctly pitched for any orientation. Be sure to specify whether tubes are horizontal or vertical, and whether airflow is horizontal or vertical when ordering.

3. GENERAL PIPING

- 3.1. Steam piping must be done in accordance with all applicable national and local codes.
- 3.2. All piping must be self-supporting and flexible enough to allow for thermal expansion and contraction. The use of flexible connections and/or swing joints is recommended.
- 3.3. Trap each coil independently. Locate trap a minimum of 14 inches below return connection of coil when on/off (non-modulating) steam supply valves are used. Locate trap a minimum of 18 inches (24 inches preferred) below return connection of coil when modulating steam supply valves are used.

- 3.4. Use only traps such as the Inverted Bucket or Float and Thermostatic type which drain continuously. When modulating steam supply valves are installed, use only a Float and Thermostatic trap (DO NOT use Inverted Bucket or Thermodynamic Disk traps).
- 3.5. Minimum operating supply steam pressure is 5 psig.
- 3.6. Never oversize control valves. Bigger is not better.
- 3.7. Coils must be installed so tubes are pitched at least $\frac{1}{4}$ inch per foot toward condensate return.
- 3.8. When condensate must be lifted into overhead or pressurized return mains, a vented condensate receiver must be installed with a properly sized steam pressure pump or some other means of pumping the condensate from the receiver into the return main (See Figures 5 and 6).
- 3.9. Install a vacuum breaker in the steam piping prior to the coil to prevent retention of condensate during shutdown. Also install a vacuum breaker on the downstream side of the coil when steam pressure is to be modulated. If you use check valves as vacuum breakers, they should be 15-degree swing checks.
- 3.10. Provide venting of non-condensable gases individually on each coil to ensure maximum heat transfer and minimum internal corrosion. Venting can be with an independent thermostatic vent, or by using a Float and Thermostatic steam trap.
- 3.11. To insure condensate drainage from steam supply lines, install a drip trap.
- 3.12. From the outlet to the steam trap, the piping should be the same size as the outlet connection.
- 3.13. To allow for servicing, manual service valves should isolate the coil and control valve.

4. PREHEAT SYSTEMS PIPING

- 4.1. When designing steam heating coils to preheat outdoor air, or to preheat a process airstream which is below freezing temperatures, use the following guidelines.
 - 4.1.1. During periods when air temperatures go below 32F (winter months) the possibility exists for steam coils to freeze and burst. This scenario can be avoided if preheat coils are correctly designed, piped, and trapped.
 - 4.1.2. The use of Colmac type BS – Basic Steam coils is recommended for this type of service. This is a single tube, single pass design (no inner tube) that can be applied with tubes oriented vertically or horizontally. Colmac type FS – Steam Distributing coils are not recommended for preheat service where freezing air temperatures are expected.
 - 4.1.3. Modulating steam supply valves are not recommended for preheat systems. The steam supply must be either on or off. To control air temperatures, use air bypass dampers. Maintain a minimum steam pressure of 5 psig to coils exposed to air temperatures below 40F.
 - 4.1.4. Design for coil face velocities less than 1000 fpm. Higher face velocities may result in burst tubes due to coil freeze-up. Design coil ductwork to distribute air evenly across the face of the coil, avoiding high velocity streams of low temperature air to hit the coil face.

4.1.5. Preheat coils can be operated successfully with Inverted Bucket or Float and Thermostatic traps that are properly sized according to the trap manufacturers recommendations. Thermodynamic Disk type traps operate intermittently (alternately fill and dump condensate) and should not be used on any steam heating coil.

4.1.6. Pipe preheat coils according to Figures 1 and 2:

FIGURE 1
PREHEAT SYSTEM PIPING
NON-MODULATING SUPPLY VALVE
VENTED RETURN

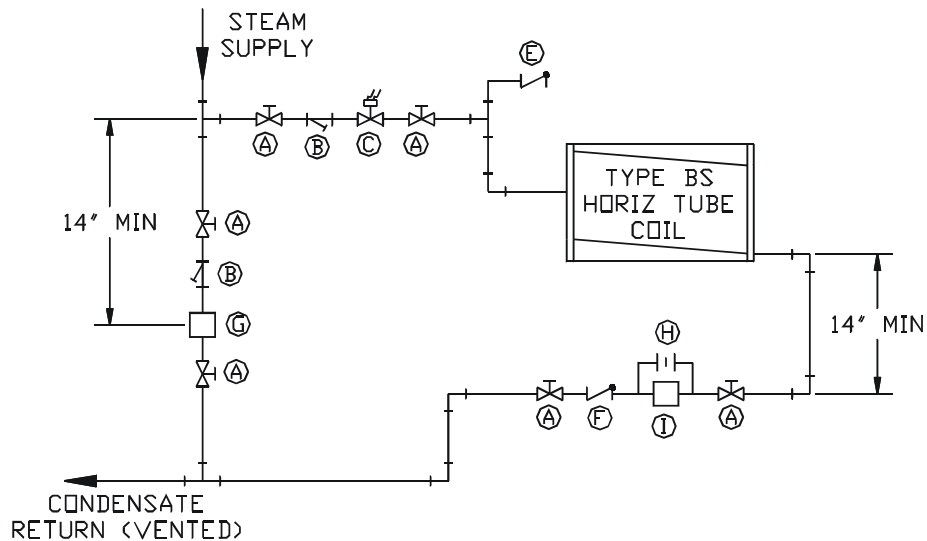

LEGEND:

- (A) SERVICE VALVE
- (B) STRAINER
- (C) ON/OFF SUPPLY
- (D) MODULATING SUPPLY VALVE
- (E) VACUUM BREAKER
- (F) CHECK VALVE (15° SWING)
- (G) DRIP TRAP
- (H) THERMOSTATIC AIR VENT
- (I) MAIN TRAP (F & T OR INVERTED BUCKET)
- (J) MAIN TRAP (F & T ONLY)
- (K) STEAM POWERED CONDENSATE PUMP

FIGURE 2
PREHEAT SYSTEM PIPING
NON-MODULATING SUPPLY VALVE
VENTED RETURN

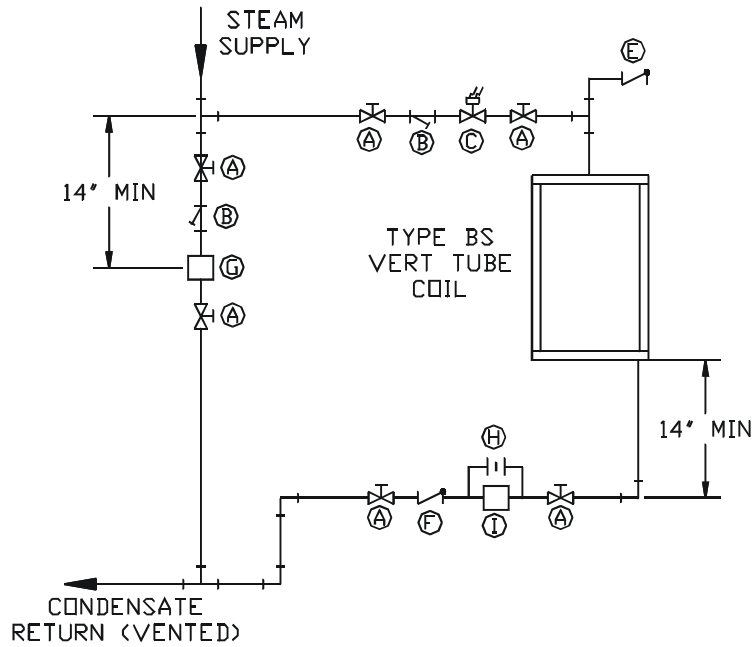

LEGEND:

- Ⓐ SERVICE VALVE
- Ⓑ STRAINER
- Ⓒ ON/OFF SUPPLY
- Ⓓ MODULATING SUPPLY VALVE
- Ⓔ VACUUM BREAKER
- Ⓕ CHECK VALVE (15° SWING)
- Ⓖ DRIP TRAP
- Ⓗ THERMOSTATIC AIR VENT
- Ⓘ MAIN TRAP (F & T OR INVERTED BUCKET)
- ⓵ MAIN TRAP (F & T ONLY)
- Ⓚ STEAM POWERED CONDENSATE PUMP

5. REHEAT SYSTEMS PIPING

- 5.1. The following guidelines apply to steam heating coils designed to reheat air that has already been preheated or has been recirculated from a heated space or process.
- 5.1.1. Normally, steam coils installed in reheat applications are fed by a modulating steam supply valve operating in response to changing air temperature. For this type of system, Colmac type FS – Steam Distributing coils are recommended. Steam distributing coils are built with an inner distribution tube having orifices which admit the live steam into the annulus between the outer and inner tubes. The inner tube orifices are carefully spaced along the length of the coil tube to effectively distribute steam over the entire face of the coil. This feature is important during periods of part load when the steam supply valve is modulating down to low steam pressures.
- 5.1.2. Type FS steam coils can be installed with tubes oriented vertically or horizontally.
- 5.1.3. It is critically important when installing type FS coils that only properly sized Float and Thermostatic type steam traps are used. This type of trap operates to continuously drain the coil of condensate at all load conditions. Inverted Bucket traps should not be used and will not operate correctly when modulating steam supply valves are installed. Thermodynamic Disk traps operate intermittently (alternately fill and dump condensate) and should not be used on any steam heating coil.
- 5.1.4. It is also critical when modulating steam supply valves are installed that vacuum breakers are installed both at the coil inlet downstream of the modulating control valve, and between the coil outlet connection and the steam trap. During part load operation, the modulating supply valve may reduce the steam pressure in the coil to the point that a vacuum can result in the coil tubes. Unless vacuum breakers are properly installed, condensate will be pulled into the coil causing premature failure due to Thermal Shock (pitting corrosion) and/or Hydraulic Shock (water hammer). The vacuum breakers serve to admit air into the coil during periods of low load, reducing coil capacity to the desired output, while allowing the condensate to be continuously and effectively drained away.
- 5.1.5. Type FS-L Steam Distributing coils (5/8" outer tubes) can be supplied with one supply connection for finned lengths up to 72". FS-L coils with finned lengths over 72" must be fed with supply steam from both ends of the coil. Type FS-X Steam Distributing coils (1" outer tubes) can be supplied with one supply connection for finned lengths up to 144".
- 5.1.6. Pipe reheat coils with modulating steam supply valves according to Figures 3 and 4:

FIGURE 3
 REHEAT SYSTEM PIPING
 MODULATING SUPPLY VALVE
 VENTED RETURN

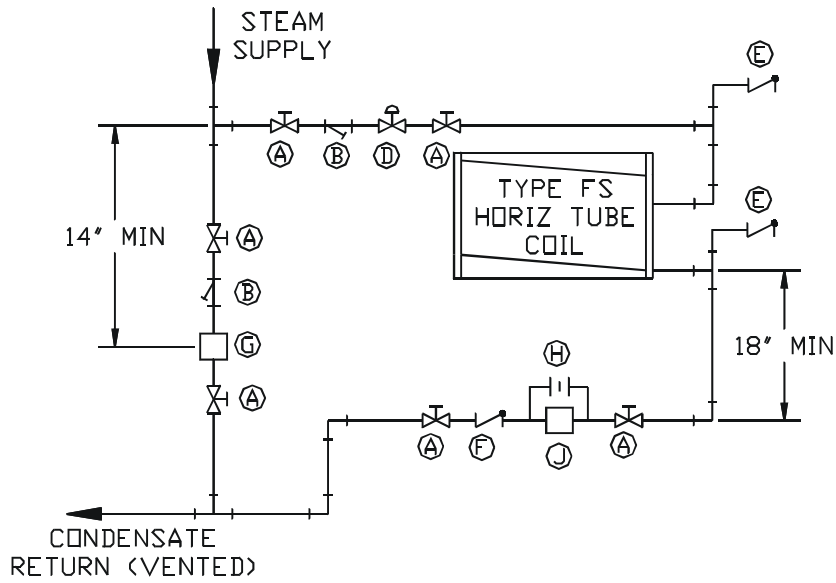

LEGEND:

- (A) SERVICE VALVE
- (B) STRAINER
- (C) ON/OFF SUPPLY
- (D) MODULATING SUPPLY VALVE
- (E) VACUUM BREAKER
- (F) CHECK VALVE (15° SWING)
- (G) DRIP TRAP
- (H) THERMOSTATIC AIR VENT
- (I) MAIN TRAP (F & T OR INVERTED BUCKET)
- (J) MAIN TRAP (F & T ONLY)
- (K) STEAM POWERED CONDENSATE PUMP

FIGURE 4
REHEAT SYSTEM PIPING
MODULATING SUPPLY VALVE
VENTED RETURN

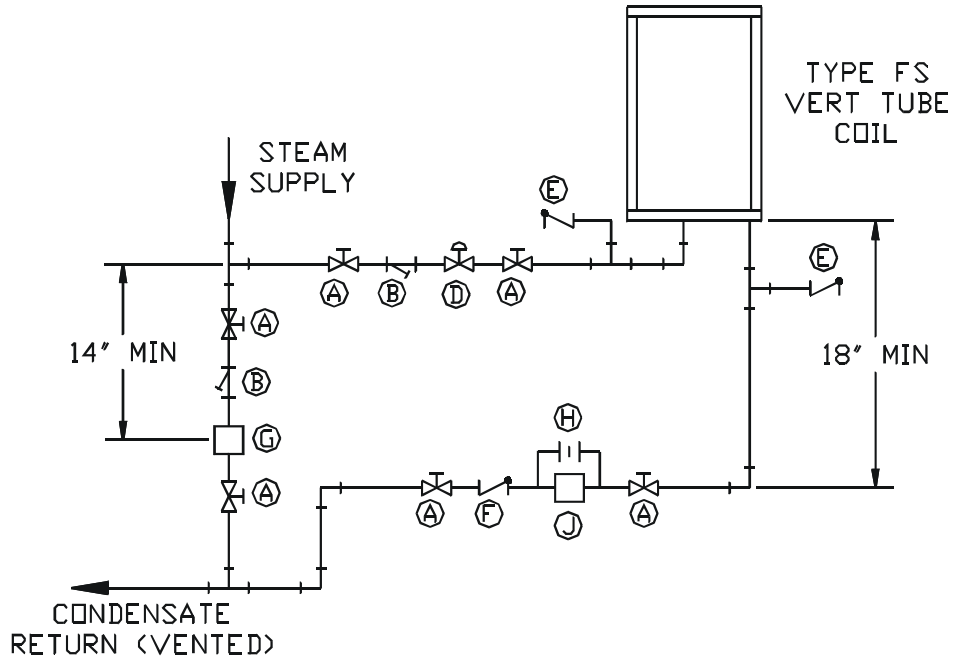

LEGEND:

- (A) SERVICE VALVE
- (B) STRAINER
- (C) ON/OFF SUPPLY
- (D) MODULATING SUPPLY VALVE
- (E) VACUUM BREAKER
- (F) CHECK VALVE (15° SWING)
- (G) DRIP TRAP
- (H) THERMOSTATIC AIR VENT
- (I) MAIN TRAP (F & T OR INVERTED BUCKET)
- (J) MAIN TRAP (F & T ONLY)
- (K) STEAM POWERED CONDENSATE PUMP

6. PROCESS HEATING PIPING

6.1. Figures 5 and 6 below show recommended piping arrangements for process heating coils with modulating and non-modulating steam supply valves having an overhead return.

6.2. A vented receiver as shown in figures 5 and 6 must be used whenever condensate must be lifted into overhead or pressurized return mains. Consult the steam trap and pump manufacturer for specific design recommendations for these types of systems. A condensate receiver with pump is the only certain way to insure that condensate is effectively cleared from the coil under all operating conditions in these types of systems.

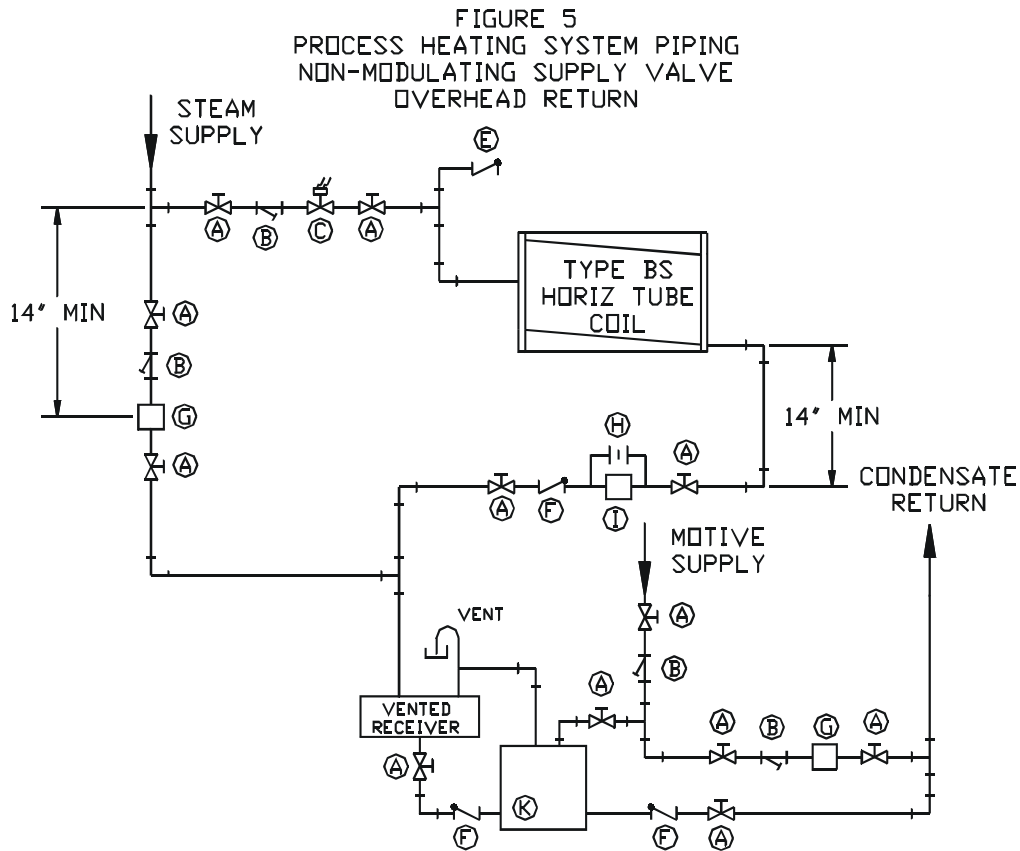

LEGEND:

- (A) SERVICE VALVE
- (B) STRAINER
- (C) ON/OFF SUPPLY
- (D) MODULATING SUPPLY VALVE
- (E) VACUUM BREAKER
- (F) CHECK VALVE (15° SWING)
- (G) DRIP TRAP
- (H) THERMOSTATIC AIR VENT
- (I) MAIN TRAP (F & T OR INVERTED BUCKET)
- (J) MAIN TRAP (F & T ONLY)
- (K) STEAM POWERED CONDENSATE PUMP

FIGURE 6
 PROCESS HEATING SYSTEM PIPING
 MODULATING SUPPLY VALVE
 OVERHEAD RETURN

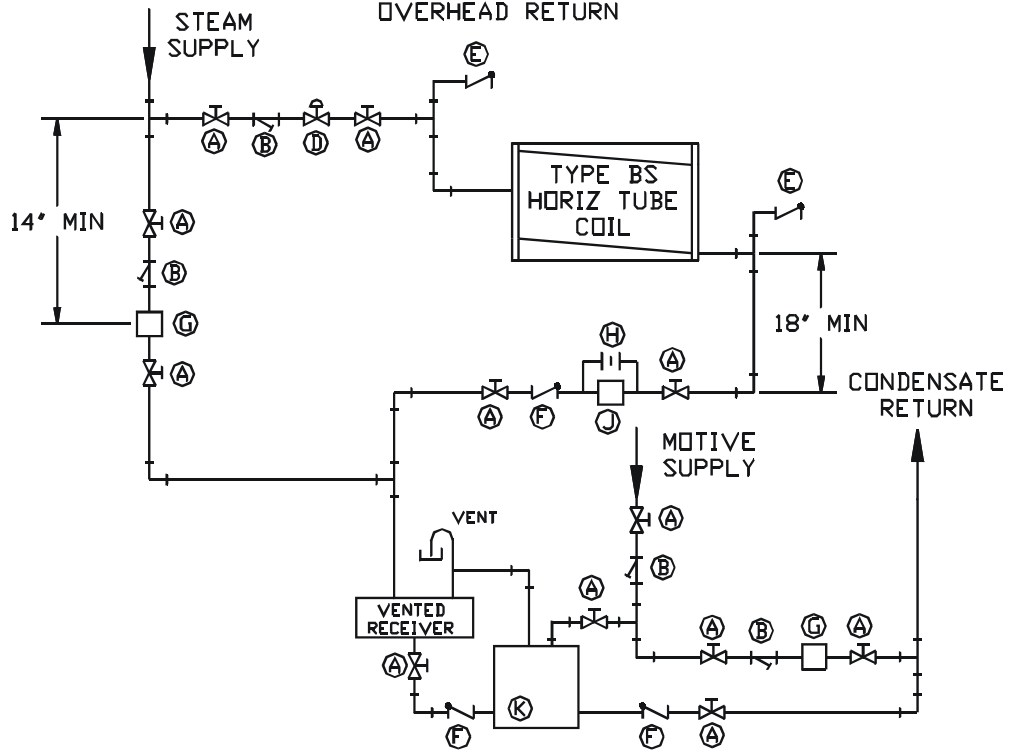

LEGEND:

- (A) SERVICE VALVE
- (B) STRAINER
- (C) ON/OFF SUPPLY
- (D) MODULATING SUPPLY VALVE
- (E) VACUUM BREAKER
- (F) CHECK VALVE (15° SWING)
- (G) DRIP TRAP
- (H) THERMOSTATIC AIR VENT
- (I) MAIN TRAP (F & T OR INVERTED BUCKET)
- (J) MAIN TRAP (F & T ONLY)
- (K) STEAM POWERED CONDENSATE PUMP

7. STARTUP

- 7.1. Once the coil is installed, it should be pressurized to 100 psig with dry nitrogen. The coil should be held at this pressure for 15 minutes to insure there are no leaks.
- 7.2. Prior to initial startup, clean coil with a commercially available coil cleaner.
- 7.3. To prevent plugging of tubes, clean the piping system and blow down all strainers prior to initial startup.
- 7.4. On startup, feed steam to the coils slowly to avoid thermal shock loadings.
- 7.5. Make sure the steam has been on for a minimum of 15 minutes prior to starting the fans or opening dampers.
- 7.6. During initial startup, tighten all bolted connections once the system stabilizes at operating temperature.

8. OPERATION

- 8.1. Keep operating pressures at or below the design limit.
- 8.2. Airflow should not vary by more than 20 % anywhere on the coil surface.
- 8.3. Air velocities should be maintained between 200 and 1500 feet per minute.
- 8.4. Drain coil to prevent corrosion during shutdown.

9. MAINTENANCE

- 9.1. To insure proper coil performance, finned surfaces and tubes should be cleaned on a regular basis using a commercially available coil cleaner. Clean finned surface from the air leaving side.
- 9.2. All drip traps, dirt pockets, steam traps, vacuum breakers, air vents, strainers, and valves should be flushed and inspected regularly.
- 9.3. A boiler water treatment should be done on occasion to remove dissolved oxygen and carbon dioxide.



Colmac reserves the right to change product design and specifications without notice.

For more information on Colmac products call us at 1-800-845-6779 or visit us online at:

WWW.COLMACCOIL.COM
