

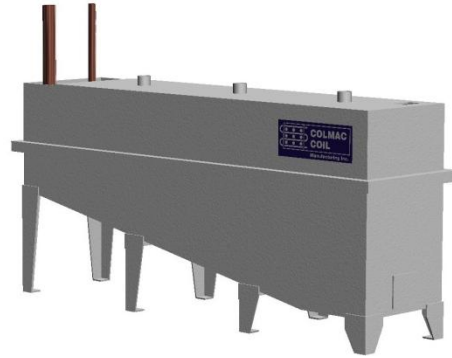

When you want Quality, specify COLMAC!



**Installation, Operation,
and Maintenance**
PN ENG00018628
Baudelot Coolers

Contents

1. GENERAL	1
2. INSTALLATION	1
3. OPERATION	9
4. MAINTENANCE	9
5. REPLACEMENT PARTS	9

1. GENERAL

1.1. For proper operation of the Baudelot Cooler, the static water level in the unit should be kept below the tube bundle. A loss of the capacity will result if the tube bundle becomes submerged. This should not become a problem if units are selected within GPM ranges given in Table 7.

1.2. Regulating Water Supply: One-Pump System

1.2.1. If it becomes desirable to decrease water flow, the hand valve shown in figure 2 can be throttled down slightly. Pressure relief valves should be used to protect the pump and piping if pressures generated by shutting the hand valve down become too great.

1.3. Regulating Water Supply: Two-Pump System

1.3.1. In this system, pump #1 must always produce slightly more GPM than pump #2. This situation will always cause lowering of the water level in the Baudelot Cooler. As the water level drops below that set by the low-limit float line and the bypass flow plus pump #2 flow becomes greater than pump #1 flow causing the water level in the Baudelot Cooler to rise.

1.3.2. Initially the hand valve controlling pump #2 flow should be set wide open. When the system comes to full operation, start closing the hand valve slowly until the solenoid valve operates intermittently.

1.3.3. Pressure relief valves should be used to protect pumps and piping if pressures generated by shutting hand valves down become too great

2. INSTALLATION

2.1. Inspection

2.1.1. Upon receipt of equipment, inspect for shortages and damage.

2.1.2. Any shortage or damage found should be noted on delivery receipt: this action gives notice that you intend to file a claim. If any shortage or damage is discovered after unpacking the unit, call the delivering carrier for a concealed damage or shortage inspection. The inspector will need related paperwork, delivery receipt, and any information indicating his liability for the damage.

2.2. Location

Locate unit so that it will not be exposed to direct sunlight or ultra violet radiation. Prolonged exposure to ultra violet radiation will cause weakening of the polyethylene tank material.

2.3. Mounting

For proper water distribution and draining, unit must be installed level.

Figure 1
Dimensions (in)

Model	A	B	C	D
HFB - 20	68	34 1/2	22	22 1/2
HFB - 40	75	40 1/2	28	28 1/2
HFB - 60	120	48 1/2	28	28 1/2
HFB - 80	140	52 1/2	28	28 1/2
HFB - 100	120	48 1/2	40	28 1/2
HFB - 120	140	52 1/2	40	28 1/2

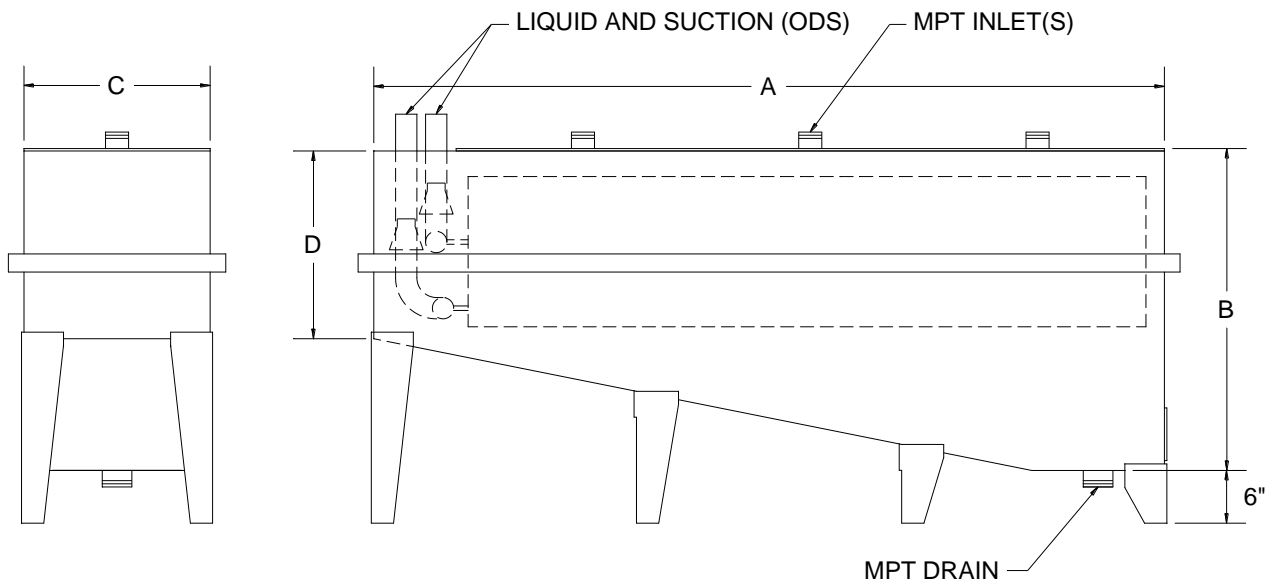

2.4. Refrigerant Piping

2.4.1. Install all refrigerant components in accordance with applicable local and national codes and in accordance with good practice for proper system operation. See Table 6 for suction connection, liquid connection and unit weights. See Table 1 and 2 for line sizing information.

2.4.2. Suction lines should be sloped towards the compressor at the rate of (1) inch per ten (10) feet for good oil return. Vertical risers of more than (5) feet should be trapped at the bottom with a P-trap for equivalent field fabricated trap.

Table 1: Refrigerant Line Capacities (Tons)

Line Size Type L Copper Tubing O.D.	Suction Line *									Liquid Line Velocity = 100FPM		
	Saturated Suction Temperature (F)									R-12	R-22	R-502
	R-12			R-22			R-502					
-40	0	+40	-40	0	+40	-40	0	+40	R-12	R-22	R-502	
5/8	-	0.25	0.56	-	0.51	1.1	0.16	0.42	0.91	3.0	3.7	2.3
7/8	0.25	0.67	1.5	0.52	1.3	2.9	0.43	1.1	2.4	6.2	7.8	4.9
1 1/8	0.51	1.4	3.0	1.1	2.7	5.8	0.87	2.2	4.8	10.5	13.2	8.3
1 3/8	0.90	2.4	5.3	1.9	4.7	10.1	1.5	3.9	8.4	16.0	20.2	12.6
1 5/8	1.4	3.8	8.3	3.0	7.5	16.0	2.4	6.2	13.3	22.7	28.5	17.9
2 1/8	3.0	7.8	17.3	6.2	15.6	33.1	5.0	12.8	27.5	39.5	49.6	31.1
2 5/8	5.3	13.9	30.5	10.9	27.5	58.3	8.8	22.6	48.4	60.9	76.5	48.0
3 1/8	8.4	22.1	48.6	17.5	44.0	92.9	14.1	36.0	77.0	86.9	109.2	68.4
3 5/8	12.6	32.9	72.2	26.0	65.4	137.8	21.0	53.5	114.3	117.6	147.8	92.6
4 1/8	17.8	46.5	101.9	36.8	92.2	194.3	29.7	75.4	161.0	152.9	192.1	120.3
5 1/8	31.9	83.3	182.0	66.0	164.5	346.6	53.2	134.6	287.1	-	-	-

* Line sizes based on pressure drop equivalent to 2 degrees per 100 linear feet. For 1 degree per 100 linear feet, use table value x .683.

Table 2: Weight of Refrigerant in Type L Copper Lines

Line Size O.D. Inches	Pounds Per 100 Lineal Feet								
	Liquid Line			Suction Line			Discharge Line		
	110°F			40°F			115°F		
	R-12	R-22	R-502	R-12	R-22	R-502	R-12	R-22	R-502
5/8	12.6	11.3	11.7	21	25	26	.65	.80	1.16
7/8	26.1	23.4	24.2	0.43	0.51	.54	1.34	1.68	2.42
1 1/8	44.8	40.0	41.5	0.74	0.87	.92	2.30	2.86	4.15
1 3/8	67.6	60.5	62.8	1.02	1.31	1.38	3.47	4.34	6.28
1 5/8	94.5	85.0	88.0	1.57	1.84	1.94	4.90	6.10	8.80
2 1/8	166.0	150.0	155.0	2.77	3.25	3.42	8.60	10.70	15.50
2 5/8	258.0	232.0	240.0	4.30	5.03	5.30	13.30	16.60	24.00
3 1/8	366.0	330.0	340.0	6.10	7.15	7.53	18.90	23.60	34.00
3 5/8	495.0	446.0	461.0	8.25	9.65	10.19	25.60	31.90	46.10
4 1/8	646.0	584.0	602.0	10.80	12.60	13.30	33.40	41.60	60.20

2.5. Expansion Valve(s)

- 2.5.1. All units require the use of external equalized expansion valve(s).
- 2.5.2. It is important that the operation of the expansion valve be checked out after the system has balanced out at the desired flow rates as there are many factors which affect the performance of an expansion valve. If the coil is being starved, it is necessary to reduce the superheat setting of the expansion valve. To obtain full evaporator performance, the expansion valve(s) should be set at the proper superheat at the lowest evaporator temperature at which the system is expected to operate.
- 2.5.3. It is recommended that for a 10° to 12° T.D. system, the valve should be adjusted to maintain 5 to 6 superheat. Select the proper thermostatic expansion valve from manufacturer's literature. The valve(s) can be mounted directly to the liquid lines provided. The expansion valve bulb(s) must be located on a straight length of suction line as close as possible to the suction header.

2.6. Water Piping: One-Pump System

- 2.6.1. Figure 2 show piping for a single pump type hydrocooler. This is a simple, cost effective way to operate a system using only one pump.
- 2.6.2. To size pump and piping, first determine GPM required by the hydrocooler. Most produce cooling applications require 15-20 GPM per sq. ft. of belt top area.

Where: Belt Top Area = Belt Width X Tunnel Length

- 2.6.3. Water flows in this range will insure that the product is thoroughly flooded. Now the water temperature drop across the Baudelot Cooler can be calculated.

$$WTD = \frac{BTUH}{500 \times GPM}$$

Where:

WTD = Water temperature drop across Baudelot Cooler

BTUH = Total Hydrocooler load in BTU/HR

GPM = Gallons per minute through Baudelot Cooler

- 2.6.4. For cost effective operation of the Baudelot Cooler, WTD should be kept between 1°F and 4°F. If WTD is less than 1°F for the GPM required, then a bypass can be installed as shown in Figure 2 to reduce water flow through the Baudelot Cooler. Since the total system BTUH remains the same, the reduction in GPM will increase the WTD as given by the equation shown above. Note that if the bypass is used, the 33°F water coming off the Baudelot Cooler should be run over product at the exiting end of the Hydrocooler tunnel.
- 2.6.5. Next, calculate pressure loss in piping between the pump and inlet to the Baudelot Cooler using the following procedure:
- List the equivalent lengths as give in Table 3 of all valves and fittings. Add to this the length of straight pipe runs to obtain the total equivalent pipe length. Divide this total length by 100.

- Obtain the pressure loss per 100 feet of pipe from Table 4 and multiply by item (1) above. This is the pressure loss through pipe, valves & fittings.
- Read the pressure loss due to elevation from Table 5.
- The total pressure drop is equal to the sum of items 2 and 3, plus an allowance of 5 pounds pressure at the inlet of the Baudelot Cooler. It is usually desirable to select pipe size so that the initial pressure drop is between 10-20 PSIG (Head in Feet = psi x 2.31)
- Now select a pump to produce the desired GPM at the calculated pressure drop. If pressure drop is too high for a given pump then select the next size larger pipe, if too low, then select the next size smaller pipe.

2.7. Water Piping: Two-Pump System

2.7.1. Figure 3 shows piping for a two pump hydrocooler. This system can be used when it becomes impractical to install the Baudelot Cooler overhead as in Figure 2.

2.7.2. See preceding section to determine GPM and for calculating pressure losses in piping.

2.7.3. Pump #1 and pump #2, and piping should initially be sized to give equal water flow rates. The bypass line with the solenoid valve should then be sized to pass approximately 10 to 20% of pump #1 flow rate at a pressure drop equal to that calculated between the bypass tee and inlet to the Hydrocooler Tunnel at the resulting reduced flow. This will be a trial and error process of selecting a bypass line size, guessing a flow rate and calculating pressure drops. If the pressure drops are not equal, then bypass flow rate must be adjusted until equal pressure drops result.

NOTE: In both types of systems, make-up water supply lines and valves must be sized to supply as much or more water than is being carried out of the Hydrocooler Tunnel by evaporation, in crating, on the product, etc.

NOTE: Provisions must be made in all systems for drain down to prevent freezing of piping in winter conditions. This might include installing drain cocks/valves in low spots, shut-off valves, etc.

Table 3: Equivalent Pipe Length of Fittings, Feet**

Pipe Size	1	1 1/4	1 1/2	2	2 1/2	3	4
Solenoid Valve	15.0	16.0	16.0	18.0*	18.0*	20.0*	-*
90° Elbow	5.2	6.6	7.4	8.5	9.3	11.0	13.0
Tee	6.6	8.7	9.9	12.0	13.0	17.0	21.0
Coup. Or Gate Valve	0.8	1.1	1.2	1.5	1.7	1.9	2.5
Globe Valve	29.0	37.0	42.0	54.0	62.0	79.0	110.0
Angle Valve	17.0	18.0	18.0	21.0	22.0	28.0	38.0

**Add equivalent length of all fittings to length of same straight pipe to obtain total length for use on table 3.

*Consult manufacture's data.

Figure 2
One-Pump System

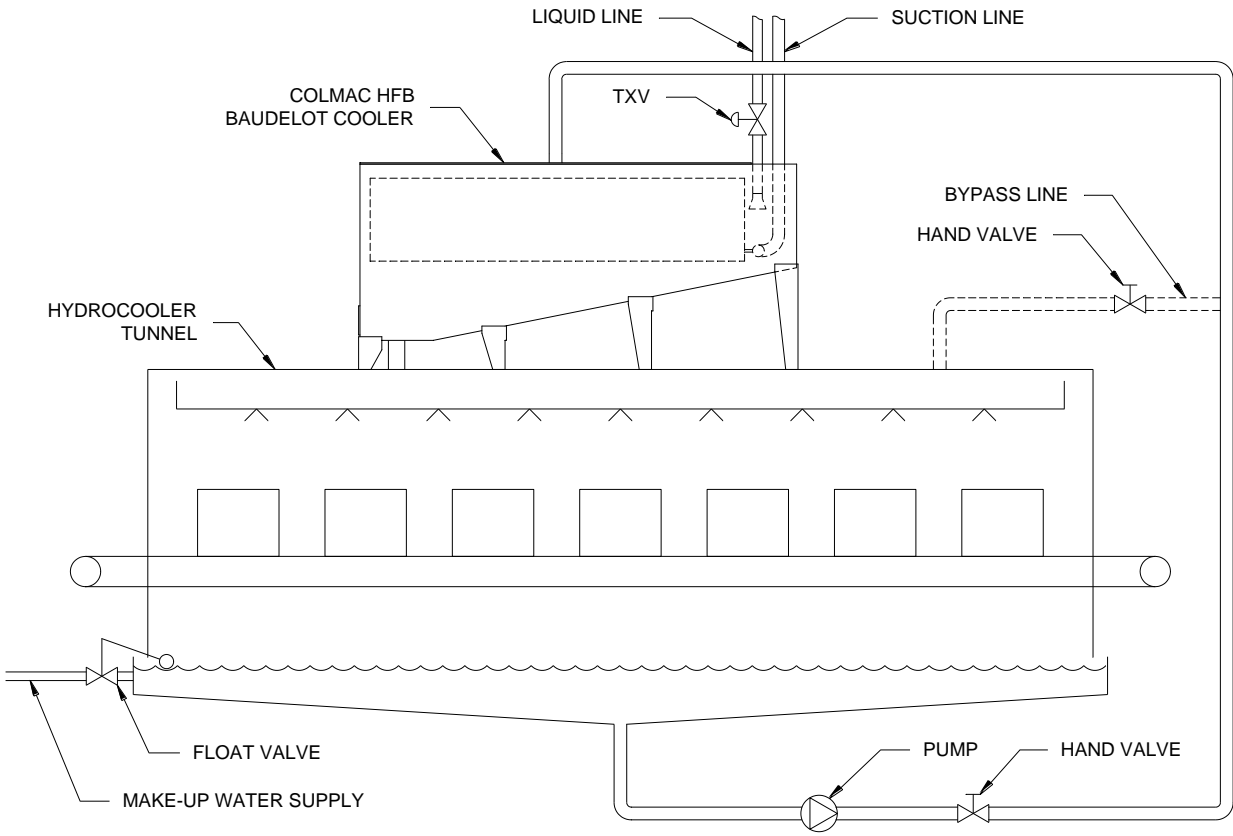

Figure 3
Two-Pump System

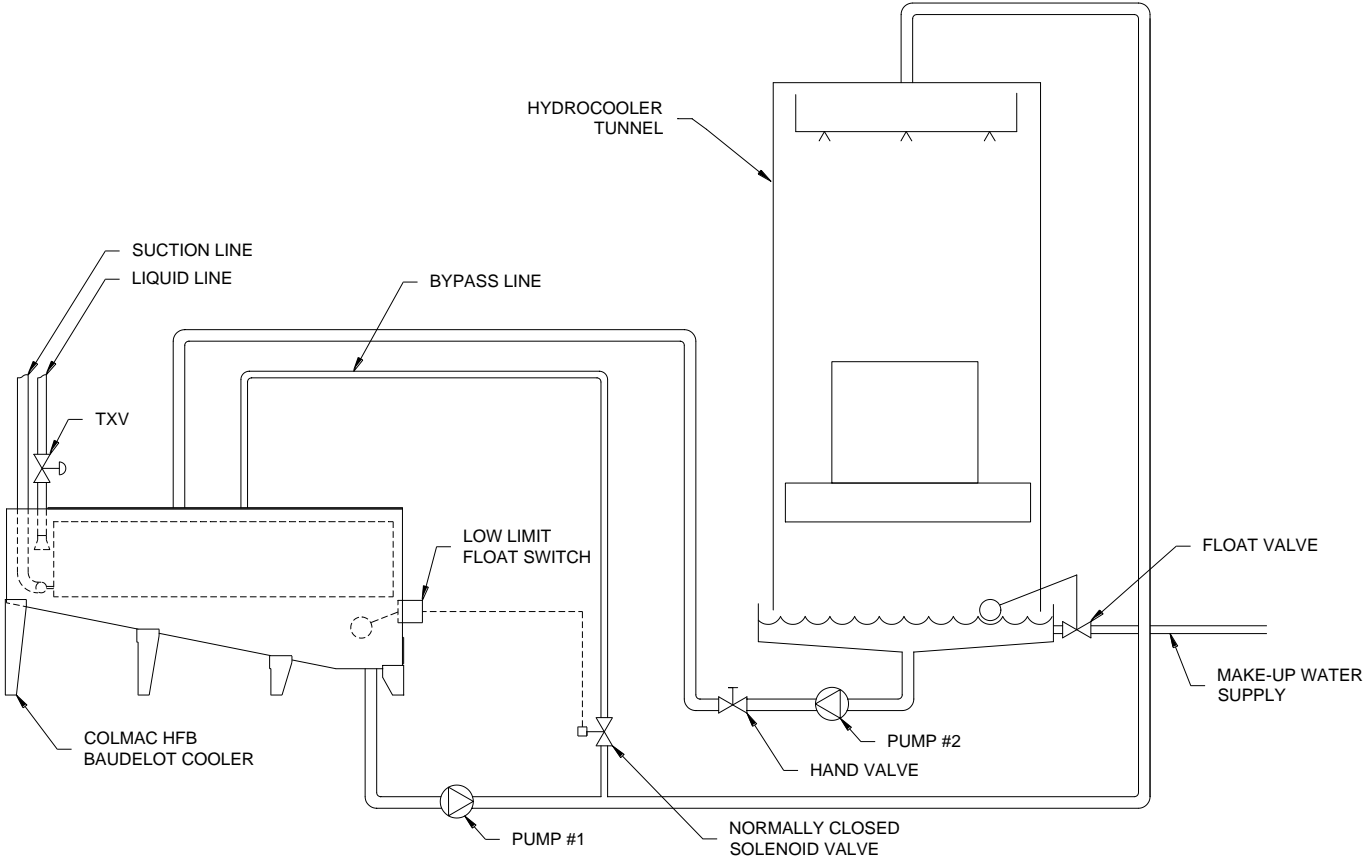

Table 4: Water Capacity of Standard Weight Pipe**

GPM at Pressure Loss Per 100 Feet of:							
Pipe Size	2 PSIG	5 PSIG	10 PSIG	15 PSIG	20 PSIG	30 PSIG	50 PSIG
1	8.0	12.8	19.1	24.0	27.8	33.9	44.5
1 1/4	17.4	26.9	39.7	49.5	57.4	70.0	91.9
1 1/2	25.9	41.0	60.0	74.1	85.5	106.5	140.0
2	51.4	79.6	116.7	144.7	166.9	203.2	268.0
2 1/2	80.9	127.6	186.0	229.0	264.6	330.8	390.0
3	144.3	227.6	331.6	407.2	467.7	575.4	-
4	292.0	469.6	671.8	826.8	961.7	-	-

** For schedule 40 steel pipe: multiply PSIG values by .86 for PVC or Copper pipe.

Table 5: Loss Of Pressure Due To Elevation*

Elevation, Feet	5	7	9	12	16	23	35	46	60
Pressure Loss, PSIG	2	3	4	5	7	10	15	20	26

*Allow 5 PSIG at unit inlet

Table 6: Physical Data

Model	Inlet MPT	Drain MPT	Liquid Conn.	Suction Conn.	# of Circuits	Dry Wt. Lbs.
HFB-20	3	3	1 3/8	2 1/8	1	415
HFB-40	(2) 3	4	(2) 1 3/8	(2) 2 1/8	2	907
HFB-60	(3) 3	4	(4) 1 3/8	(4) 2 1/8	4	1348
HFB-80	(3) 3 1/2	4	(4) 1 3/8	(4) 2 1/8	4	1616
HFB-100	(3) 4	6	(4) 1 5/8	(4) 2 5/8	4	1957
HFB-120	(3) 4	6	(4) 1 5/8	(4) 2 5/8	4	2318

Table 7: Specifications

Model	5°TD	Capacity, MBH* 10° TD	15° TD	Prime Surf.** Sq. Ft.	GPM Range
HFB-20	81.8	163.5	245.3	109	54-175
HFB-40	163.5	327.0	490.5	218	106-300
HFB-60	268.5	537.0	805.5	358	160-400
HFB-80	318.0	636.0	954.0	424	210-440
HFB-100	408.8	817.5	1226.3	545	270-900
HFB-120	490.5	981.0	1471.5	654	325-1000

*TD is the difference between entering liquid temperature and saturated suction temperature.

**Tubing surface only (does not include frame, headers, etc.)

3. OPERATION

3.1. Before Start Up

- 3.1.1. Make sure all piping is done completely and in accordance with good practice.
- 3.1.2. Make sure that suction, discharge and receiver service valves are open.
- 3.1.3. Make sure unit is mounted securely and is leveled.
- 3.1.4. Fill sumps, tanks and water piping with water

3.2. After Start Up

- 3.2.1. Check the compressor for possible overload immediately after start-up.
- 3.2.2. Check the system for proper refrigerant and oil charge.
- 3.2.3. Check the expansion valve superheat setting. It is important that the valve is set properly for efficient operation.
- 3.2.4. Monitor water levels and adjust water flow as required.

4. MAINTENANCE

- 4.1. The system should be checked periodically for proper water levels and operation of pumps, valves, and switches. Also check the following on a routine basis during operation:
 - 4.2. Clean sump screens.
 - 4.3. Check refrigerant system for charge level, oil level, and any evidence of leaks.
 - 4.4. Inspect and clean water distributing pan(s)

5. REPLACEMENT PARTS

When contacting Colmac for service or replacement parts, refer to the model number and serial number stamped on the unit serial plate. If replacement parts are required, mention date of installation of the unit and date of failure along with an explanation of the malfunction and description of the parts required.



Colmac reserves the right to change product design and specifications without notice.

For more information on Colmac products call us at 1-800-845-6779 or visit us online at:

WWW.COLMACCOIL.COM
